

# 8000, 87000 & 88000 SERIES

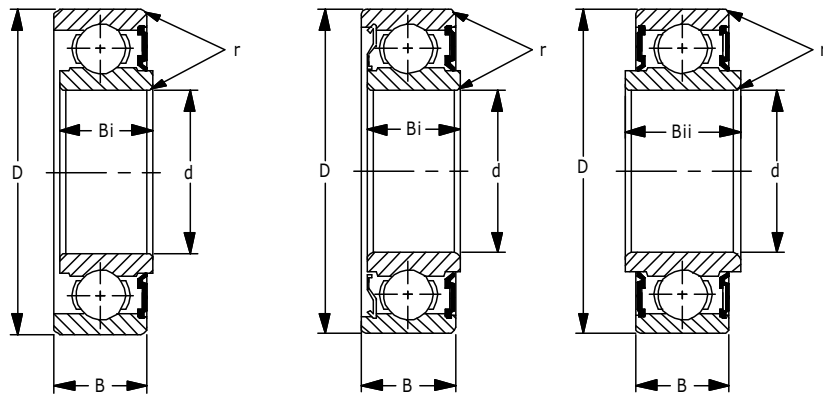

For applications where dirt exclusion and lubrication retention are primary considerations. This series is designed with an extended inner race to meet the exact dimensions of the felt series. Varying the contact pressure of the lip seal allows these bearings to be used for extremely high speed as well as for normal applications. The 88000 series, identical to the 8000 and 87000 series, has the added advantage of a Buna N Seal on both sides of the bearing. Identical in dimension to the felt series, this sealed bearing prevents contamination from entering the raceway.

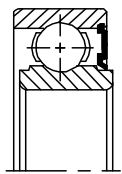

8000  
SEAL

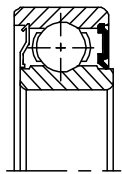

87000  
SEAL AND SHIELD

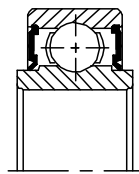

88000  
DOUBLE SEALED

Units: Inches  
Metric

Part Number	Bore d	OD D	Outer Ring Width B	Inner Ring Width		Overall Width	Fillet Radius		snap ring dimensions		snap ring groove dimensions		Basic Load Ratings lbs N		Weight lbs Kg		
				B <sub>i</sub>	B <sub>ii</sub>		r	r <sub>2</sub>	D <sub>2</sub> Max	f Max	a Max	b Min	Dynamic C	Static Cor	8000	87000	88000
8035 87035 88035	.1969	.7480	.3150	.3860	.4970	.4063	.012						525	199	.022	.023	.026
	5	19	8	9.804	12.624	10.319	.3						2,335	885	.010	.010	.012
8036 87036 88036	.2362	.7480	.3150	.3860	.4970	.4063	.012	.008	.878	.028	.068	.031	525	199	.024	.025	.027
	6	19	8	9.804	12.624	10.319	.3	.2	22.3	.7	1.73	.8	2,335	885	.011	.011	.012
8006 87006 88006	.2362	.9449	.3150	.3860	.4970	.4063	.012	.012	1.102	.028	.068	.031	750	315	.046	.048	.055
	6	24	8	9.804	12.624	10.319	.3	.3	28	.7	1.73	.8	3,336	1,401	.021	.022	.025
8037 87037 88037	.2756	.8661	.3150	.3860	.4970	.4063	.012	.012	1.024	.028	.068	.031	750	315	.037	.039	.043
	7	22	8	9.804	12.624	10.319	.3	.3	26	.7	1.73	.8	3,336	1,401	.017	.018	.020
8007 87007 88007	.2756	.9449	.3150	.3860	.4970	.4063	.012	.012	1.102	.028	.068	.031	900	355	.045	.047	.051
	7	24	8	9.804	12.624	10.319	.3	.3	28	.7	1.73	.8	4,003	1,579	.020	.021	.023
8038 87038 88038	.3150	.8661	.3150	.3860	.4970	.4063	.012	.012	1.024	.028	.068	.031	750	315	.036	.038	.040
	8	22	8	9.804	12.624	10.319	.3	.3	26	.7	1.73	.8	3,336	1,401	.016	.017	.018
8008 87008 88008	.3150	.9449	.3150	.3860	.4970	.4063	.012	.012	1.102	.028	.068	.031	900	355	.043	.044	.048
	8	24	8	9.804	12.624	10.319	.3	.3	28	.7	1.73	.8	4,003	1,579	.022	.020	.022
8039 87039 88039	.3543	1.0236	.3150	.3860	.4970	.4063	.025	.012	1.181	.028	.068	.031	1,030	440	.051	.053	.057
	9	26	8	9.804	12.624	10.319	.6	.3	30	.7	1.73	.8	4,581	1,957	.023	.024	.026
8009 87009 88009	.3543	1.1811	.3543	.4800	.6457	.5000	.025	.020	1.437	.044	.081	.053	1,150	540	.078	.095	.105
	9	30	9	12.192	16.401	12.700	.6	.5	36.5	1.12	2.06	1.35	5,115	2,402	.035	.043	.048
8500 87500 88500	.3937	1.1811	.3543	.4800	.6457	.5000	.025	.020	1.366	.044	.081	.053	1,150	540	.075	.077	.091
	10	30	9	12.192	16.401	12.700	.6	.5	34.7	1.12	2.06	1.35	5,115	2,402	.034	.035	.041
8011 87011 88011	.4331	1.2598	.3937	.4800	.6063	.5000	.025	.020	1.445	.044	.081	.053	1,370	615	.099	.101	.104
	11	32	10	12.192	15.400	12.700	.6	.5	36.7	1.12	2.06	1.35	6,094	2,736	.045	.046	.047
8501 87501 88501	.4724	1.2598	.3937	.4800	.6063	.5000	.025	.020	1.445	.044	.081	.053	1,370	615	.095	.097	.099
	12	32	10	12.192	15.400	12.700	.6	.5	36.7	1.12	2.06	1.35	6,094	2,736	.043	.044	.045

\*Maximum fillet which corner radius of bearing will clear.



# 8000, 87000 & 88000 SERIES (continued)

The basic 6300 series ball complement with two Buna N seals. Extended inner rings make this series perfectly interchangeable with the standard 8600, 87600 and 88600 felt series. By increasing contact pressure, the 6300 series can be used for rugged farm applications as well as for electric motors. Consult the Peer sales engineer for your specific requirements.

Units: Inches  
Metric

Part Number	Bore d	OD D	Outer Ring Width B	Inner Ring Width		Overall Width	Fillet Radius		snap ring dimensions		snap ring groove dimensions		Basic Load Ratings lbs N		Weight lbs Kg		
				B <sub>i</sub>	B <sub>ii</sub>		r	r <sub>2</sub>	D <sub>2</sub> Max	f Max	a Max	b Min	Dynamic C	Static Cor	8000	87000	88000
8013 87013 88013	.5118	1.2598	.3937	.4800	.6063	.5000	.025	.020	1.445	.044	.081	.053	1,370	615	.091	.093	.095
	13	32	10	12.624	15.400	12.700	.6	.50	36.7	1.12	2.06	1.35	6,094	2,736	.041	.042	.043
8014 87014 88014	.5512	1.3780	.4331	.4800	.5669	.5000	.025	.020	1.563	.044	.081	.053	1,740	805	.111	.115	.125
	14	35	11	12.624	14.399	12.700	.6	.50	39.7	1.12	2.06	1.35	7,740	3,581	.050	.052	.057
8502 87502 88502	.5906	1.3780	.4331	.4800	.5669	.5000	.025	.020	1.563	.044	.081	.053	1,740	805	.106	.108	.119
	15	35	11	12.624	14.399	12.700	.6	.50	39.7	1.12	2.06	1.35	7,740	3,581	.048	.049	.054
8016 87016 88016	.6299	1.3780	.4331	.4800	.5669	.5000	.025	.020	1.563	.044	.081	.053	1,740	805	.101	.105	.114
	16	35	11	12.624	14.399	12.700	.6	.50	39.7	1.12	2.06	1.35	7,740	3,581	.046	.048	.052
8602 87602 88602	.5906	1.6535	.5118	.5512	.6693	.5906	.040	.020	1.823	.044	.081	.053	2,570	1,220	.188	.193	.210
	15	42	13	14.000	17.000	15.000	1.0	.50	46.3	.112	2.06	1.35	11,451	5,427	.085	.088	.095
8503 87503 88503	.6693	1.5748	.4724	.5380	.6536	.5625	.025	.020	1.756	.044	.081	.053	2,160	1,030	.150	.154	.166
	17	40	12	13.665	16.601	14.288	.6	.50	44.6	1.12	2.06	1.35	9,608	4,581	.068	.070	.075
8603 87603 88603	.6693	1.8504	.5512	.5906	.7087	.6299	.040	.020	2.075	.044	.097	.053	3,050	1,470	.254	.257	.279
	17	47	14	15.000	18.000	16.000	1.0	.50	52.7	1.12	2.46	1.35	13,566	6,539	.115	.117	.127
8504 87504 88504	.7874	1.8504	.5512	.6000	.6988	.6250	.040	.020	2.075	.044	.097	.053	2,890	1,500	.232	.237	.259
	20	47	14	15.240	17.750	15.875	1.0	.50	52.7	1.12	2.46	1.35	12,855	6,672	.105	.108	.118
8604 87604 88604	.7874	2.0472	.5906	.7087	.9055	.7480	.040	.020	2.280	.044	.097	.053	3,600	1,770	.345	.352	.398
	20	52	15	18.000	23.000	19.000	1.0	.50	52.7	1.12	2.46	1.35	16,013	7,873	.157	.160	.181
8505 87505 88505	.9843	2.0472	.5906	.6000	.6594	.6250	.040	.020	2.280	.044	.097	.053	3,150	1,770	.287	.292	.304
	25	52	15	15.240	16.749	15.875	1.0	.50	57.9	1.12	2.46	1.35	14,011	7,873	.130	.133	.138
8605 87605 88605	.9843	2.4409	.6693	.8268	.9843	.8268	.040	.020	2.665	.067	.129	.075	4,750	2,460	.590	.600	.650
	25	62	17	21.000	25.000	21.000	1.0	.50	67.7	1.7	3.28	1.39	21,128	10,942	.268	.272	.295
8026 87026 88026	1.0236	2.0472	.5906	.6000	.6594	.6250	.040	.020	2.280	.044	.097	.053	3,150	1,770	.277	.282	.294
	26	52	15	15.240	16.749	15.875	1.0	.50	57.9	1.12	2.46	1.35	14,011	7,873	.126	.128	.133
8506 87506 88506	1.1811	2.4409	.6299	.7480	.9449	.7874	.040	.020	2.665	.067	.129	.075	4,400	2,540	.495	.506	.571
	30	62	16	19.000	24.000	20.000	1.0	.50	67.7	1.7	3.28	1.9	19,571	11,298	.225	.230	.259
8606 87606 88606	1.1811	2.8346	.7480	.9055	1.0630	.9055	.040	.020	3.094	.067	.129	.075	6,000	3,400	.860	.890	.970
	30	72	19	23.000	27.000	23.000	1.0	.50	78.5	1.7	3.28	1.9	26,688	15,123	.390	.404	.440
8507 87507 88070	1.3780	2.8346	.6993	.7874	.9843	.8268	.040	.020	3.094	.067	.129	.075	5,750	3,450	.695	.708	.765
	35	72	17	20.000	25.000	21.000	1.0	.50	78.6	1.7	3.28	1.9	25,576	15,346	.316	.321	.347
8607 87607 88607	1.3780	3.1496	.8268	.9843	1.1417	.9843	.060	.020	3.409	.067	.129	.075	7,500	4,300	1.10	1.12	1.20
	35	80	21	25.000	29.000	25.000	1.5	.50	86.6	1.7	3.28	1.9	33,360	19,126	.499	.508	.545
8508 87508 88508	1.5748	3.1496	.8268	.9449	1.0630	.9449	.040	.020	3.409	.067	.129	.075	6,550	4,000	1.03	1.07	1.18
	40	80	21	24.000	27.000	24.000	1.0	.50	86.6	1.7	3.28	1.9	29,134	17,792	.468	.486	.536
8608 87608 88608	1.5748	3.5433	.9055	1.0630	1.2205	1.0630	.060	.020	3.799	.097	.129	.106	9,150	5,400	1.53	1.56	1.65
	40	90	23	27.000	31.000	27.000	1.5	.50	96.5	2.46	3.28	2.7	40,699	24,019	.695	.708	.749
8509 87509 88509	1.7717	3.3465	.8268	.9449	1.0630	.9449	.040	.020	3.606	.067	.129	.075	7,350	4,600	1.19	1.20	1.22
	45	85	21	24.000	27.000	24.000	1.0	.50	91.6	1.70	3.28	1.90	32,693	20,461	.540	.545	.554
8609 87609 88609	1.7717	3.9370	.9843	1.1811	1.3780	1.1811	.060	.020	4.193	.097	.129	.106	11,900	7,200	1.96	2.01	2.19
	45	100	25	30.000	35.000	30.000	1.5	.50	106.5	2.46	3.28	2.7	52,931	32,026	.890	.913	.994
8510 87510 88510	1.9685	3.5433	.8661	1.0236	1.1811	1.0236	.040	.020	3.799	.097	.129	.106	7,900	5,200	1.27	1.30	1.40
	50	90	22	26.000	30.000	26.000	1.0	.50	96.5	2.46	3.28	2.7	35,139	23,130	.577	.590	.636
8511 87511 88511	2.1654	3.9370	.9055	1.0630	1.2205	1.0630	.060	.020	4.193	.097	.129	.106	9,750	6,550	1.60	1.64	1.78
	55	100	23	27.000	31.000	27.000	1.5	.50	106.5	2.46	3.28	2.7	43,368	29,134	.726	.745	.808
8512 87512 88512	2.3622	4.3307	.9843	1.1417	1.2992	1.1417	.060	.020	4.591	.097	.129	.106	11,800	8,150	2.11	2.10	2.34
	60	110	25	29.000	33.000	29.000	1.5	.50	116.6	2.46	3.28	2.7	52,486	36,251	.958	.953	1.062
8513 87513 88513	2.5591	4.7244	1.0236	1.2205	1.4173	1.2205	.060	.020	5.106	.111	.160	.122	12,900	9,000	2.79	2.80	3.05
	65	120	26	31.000	36.000	31.000	1.5	.50	129.7	2.82	4.06	3.1	57,379	40,032	1.267	.013	1.385
8514 87514	2.7559	4.9213	1.1024	1.2992	1.4961	1.2992	.060	.020	5.303	.111	.160	.122	14,000	9,400	3.00	3.08	
	70	125	28	33.000	38.000	33.000	1.5	.50	134.7	2.82	4.06	3.1	62,272	44,035	1.362	1.398	

\*Maximum fillet which corner radius of bearing will clear.