

Shaft Seals & Oil Bath Seals





PEER is a dynamic and customer focused bearing manufacturer delivering valued solutions to a global market...

- Valued bearing solutions for agricultural, electrical, fluid, HVAC, lawn & garden, material handling and transmission industries
- Global application engineering support
- TS-16949 certified manufacturing facilities
- Dedicated research and development center
- Testing capabilities include: fatigue life, noise/vibration, mud slurry and salt spray testing
- Flexible manufacturing to allow for low to high volume production
- Customer service excellence



Material and specifications	2
Fluid compatibility	3
Metal case and spring specifications	3
Storage and handling of shaft seals	4
Shaft recommendations and tolerances	5
Housing recommendations and tolerances.....	6
Seal tolerances.....	7, 8
Lubrication	8
Recommended installation methods	9, 10
Improper installation methods.....	11
Standard seal designs	12
Outer case and lip designations	13
Lip, case and spring material designations	13
Engineering information sheet	14
Metric conversion chart	15
A complete listing of PEER shaft seals.....	16
Inch parts listing – shaft seals	17-24
Metric parts listing – shaft seals	25-27
Inch interchange – shaft seals	28-43
Metric interchange – shaft seals.....	44-49
Oil bath seals; materials and specifications.....	50
Standard oil bath seal designs	51
Oil bath seal installation.....	52
Oil bath seal parts listing and interchange – POBS 5000 series.....	53-55
Oil bath seal parts listing and interchange – POBS 7000 series.....	56, 57
PEER’s sales and distribution offices	58



Materials and Specifications

GENERAL ELASTOMER INFORMATION

BASE POLYMER	NITRILE	POLYACRYLATE	SILICONE	FLUOROELASTOMER
Material Code	N	P	S	V
TEMPERATURE RANGE*	-40° to 250°F -40° to 121°C	-30° to 300°F -34° to 149°C	-80° to 350°F -62° to 176°C	-40° to 400°F -40° to 204°C
Oil Resistance	E	E	G	E
Acid Resistance	G	F	F	F
Alkali Resistance	G	X	X	F
Water Resistance	G	F	G	G
Heat Resistance	G	E	E	E
Cold Resistance	G	F	E	G
Wear Resistance	E	E	G	E
Ozone Resistance	G	E	E	E

* Maximum temperature limits dependent on other operating conditions.

** PTFE, Ethylene Acrylate and other elastomers are available.

E = Excellent G = Good, for most applications

F = Fair, can be used if no other materials are available X = Not recommended

	ADVANTAGES	DISADVANTAGES
NITRILE	Commonly referred to as Buna-N or NBR. Low cost. Good resistance to petroleum oils, water, silicone oils, greases and glycol based fluids. Good abrasion resistance, cold flow and tear resistance.	Poor resistance to ozone and weather aging.
POLYACRYLATE	Polymerised acrylic acidesters. Good resistance to mineral oils, hypoid gear oils, E.P. additives, greases, aging and flex cracking.	Fair cold temperature limit. Lower mechanical strength. Higher cost than Nitrile. Poor dry running ability and water resistance.
SILICONE	Broad temperature range. Good ozone resistance. Resistant to compression set.	Low resistance to hydrocarbon fluids like gasoline and paraffin or steam above 50 psi. Higher cost than Polyacrylate.
FLUOROELASTOMER	Good temperature resistance. Compatible with a wide range of fluids. Commonly chosen as a high temperature replacement for Nitrile or Polyacrylate.	Fair resistance to water and dry running. High cost.

Fluid Compatibility & Metal Case Spring Specifications



FLUID COMPATIBILITY

TYPE OF FLUID TO BE SEALED		LIP MATERIAL			
		NITRILE	POLYACRYLATE	SILICONE	FLUOROELASTOMER
Engine Oil	SAE 30 Wt.	E	E	E	E
	SAE 10 Wt.	E	E	G	E
Gear Oil	Super Gear	E	E	F	E
	Hypoid Gear	G	G	X	E
Turbine Oil No.2		G	G	G	E
Machine Oil No.2		G	G	F	E
Auto. Transmission Fluid		E	E	F	E
Petroleum Base Lube Oil		E	E	F	E
Gasoline		F	X	X	E
Light Oil/Kerosene		F	X	X	G
Cutting Oil		E	G	F	E
Grease		E	E	E	E
E.P. Lubricants		G	E	X	E
Water-Glycol		E	X	G	F
Alcohol		E	X	G	F
20% Hydrochloric Acid Solution		F	F	F	E
30% Sulfuric Acid Solution		F	F	X	E

E = Excellent G = Good, for most applications
 F = Fair, can be used if no other materials are available X = Not recommended

METAL CASE AND SPRING SPECIFICATIONS

CASE					
SAE No.	AISI No.	Material	Application	Cost	Suggestion
1008 - 1010	1008 - 1010	Carbon steel	General	Low	
30304	304	Stainless steel	Corrosion resistant conditions	High	Using a fully rubber covered design with carbon steel case can reduce cost.

SPRING				
SAE No.	AISI No.	Material	Application	Cost
1070 - 1080	1070 - 1080	Piano wire	General	Low
30304	304	Stainless steel	Corrosion resistant conditions	High



Storage & Handling of Shaft Seals

Prior to installation, careful storage and handling of oil seals is necessary. This will help avoid hazards which would negatively affect the service life of the seal.

General Storage

Oil seals should be stored in a dust free and dry atmosphere and they must be kept in their original wrapping, which should only be opened just prior to installation.

Storage areas should be cool (60° to 90°F) with average (40 to 70%) humidity. Excessive humidity will deteriorate some elastomers as well as cause corrosive damage to metal casings and springs.

Excessive heat or exposure to ozone can cause premature aging of some sealing elements. This premature aging will significantly reduce sealing life. Avoid storage near heat sources and keep away from direct or reflected sunlight and electrical equipment that may generate ozone.

Store seals in a horizontal position and always use on a first-in first-out basis to avoid ageing on the shelf.

Under proper storage conditions the following shelf life can be expected from elastomers noted below:

Type of Lip Material	Shelf Life
Nitrile - N	5 to 10 years
Polyacrylate - P	Up to 20 years
Silicone - S	Up to 20 years
Fluoroelastomer -V	Up to 20 years
PTFE - T	Indefinite

Mechanical Storage

Failed oil seals can often be traced back to improper handling or storage.

- Never store in unprotected open bins. Keep in the original packing.
- Keep seals clean.
- Never tag seals.
- Never hang seals on a hook.
- Avoid dropping seals. This may dislodge the spring, distort or contaminate the seal.
- Never reuse old or damaged seals.

Shaft Recommendations & Tolerances



Shaft Material

Medium carbon steel or stainless steel shafts are recommended for optimum seal performance. The processes of heat treating or nitriding are strongly suggested. Stainless steel is best suited in an application where water must be sealed at a low surface velocity.

Shaft Hardness

Shaft hardness is an important factor to prevent excessive wear, deformation, scratches or nicks, and to allow proper machining for correct roughness.

Under normal conditions a minimum hardness of 45 HRC is recommended where the sealing lip contacts the shaft. 55 HRC is suggested where lubrication is doubtful, shaft speed is greater than 14m/sec. or abrasive matter is present.

Shaft Roughness

Surface roughness of the shaft is very important as it has a direct affect on the amount of lip wear. The recommended roughness is:

Rotating shaft: 10 to 20 μ inch Ra (.25 to 0.50 μ M Ra).

Reciprocating shaft: 5 to 10 μ inch Ra (.13 to 0.25 μ M Ra).

Rifling marks must not be present in the area of the contact surface. This finish should not be overlooked as it greatly influences the lip heat.

Shaft Tolerances

The shaft tolerance range should be decreased for high speed or pressure applications.

SHAFT DIAMETER - INCH	TOLERANCE
Up to 4.000	+/- 0.003
4.001 to 6.000	+/- 0.004
6.001 to 10.000	+/- 0.005
Over 10.000	+/- 0.006

SHAFT DIAMETER - METRIC	TOLERANCE
Up to 100	+/- 0.08
100.10 to 150.00	+/- 0.10
150.10 to 250.00	+/- 0.13



Housing Recommendations & Tolerances

Housing Material

Steel and cast iron provide a good surface for both rubber and metal O.D. seals. For soft alloy (aluminum), plastic or nylon housings, seals with a rubber O.D. provide better sealing capacity. It is important to note that soft alloy, plastic and nylon housings have higher rates of thermal expansion. This should be considered when selecting a seal that will be used in an application with such a housing.

Housing Material

A housing inside diameter roughness of approximately 125 micro inches Ra (3.2 micrometer), or smoother, should be maintained to avoid leakage. For Aluminum, the finish should be 100 to 200 micro inches Ra (2.5 to 5.0 micrometer).

Housing Configuration

The lead corner of the seal housing should be chamfered and free of burrs. The inside corner of the seal housing should have a maximum radius of .031" (.079mm).

Housing Tolerances

Housing Diameter - Inch	Housing Tolerance
Up to 3.000	+/- 0.001
3.001 to 6.000	+/- 0.0015
6.001 to 10.000	+/- 0.002
10.001 to 20.000	+0.002 / -0.004
20.001 to 40.000	+0.002 / -0.006
40.001 to 60.000	+0.002 / -0.010

Housing Diameter - Metric	Housing Tolerance
Over 6 to 10	+0.022 / -0.000
Over 10 to 18	+0.027 / -0.000
Over 18 to 30	+0.033 / -0.000
Over 30 to 50	+0.039 / -0.000
Over 50 to 80	+0.046 / -0.000
Over 80 to 120	+0.054 / -0.000
Over 120 to 180	+0.063 / -0.000
Over 180 to 250	+0.072 / -0.000
Over 250 to 315	+0.081 / -0.000
Over 315 to 400	+0.089 / -0.000
Over 400 to 500	+0.097 / -0.000

There are many factors to take into consideration when selecting a seal design according to the application and operating conditions. PEER seals are manufactured to precise tolerances. To assure the necessary press fit see the tables below.

Note that the tolerances in these tables apply to ferrous materials only. Because non-ferrous materials have a higher rate of thermal expansion please contact the PEER engineering department for further assistance.

Seal Width Tolerances

	Width Range	Tolerance
Inch	All	+/- 0.015
Metric	Up to 10	+/- 0.20
	Over 10	+/- 0.30

Seal O.D. Tolerances

Bore Diameter - Inch	Nominal Press-Fit		O.D. Tolerance	
	Metal O.D.	Rubber O.D.	Metal O.D.	Rubber O.D.*
Up to 1.000	+0.004	+0.006	+/- 0.002	+/- 0.003
1.001 to 2.000	+0.004	+0.007	+/- 0.002	+/- 0.003
2.001 to 3.000	+0.004	+0.008	+/- 0.002	+/- 0.003
3.001 to 4.000	+0.005	+0.010	+/- 0.002	+/- 0.004
4.001 to 6.000	+0.005	+0.010	+0.003 / -0.002	+/- 0.004
6.001 to 8.000	+0.006	+0.010	+0.003 / -0.002	+/- 0.004
8.001 to 10.000	+0.008	+0.010	+0.004 / -0.002	+/- 0.004
10.001 to 20.000	+0.008	+0.010	+0.006 / -0.002	+/- 0.004
20.001 to 40.000	+0.008	+0.010	+0.008 / -0.002	+/- 0.004
40.001 to 60.000	+0.008	+0.010	+0.010 / -0.002	+/- 0.004

* Rubber covered seals using materials other than Nitrile may require different tolerances to be agreed upon between PEER and the end-user.



Seal Tolerances

Bore Diameter - Metric	Nominal Press-Fit	
	Metal O.D.	Rubber O.D.*
Up to 50	+0.20	+0.30
	+0.10	+0.15
Over 50 to 80	+0.23	+0.35
	+0.13	+0.20
Over 80 to 120	+0.25	+0.35
	+0.15	+0.20
Over 120 to 180	+0.28	+0.45
	+0.18	+0.25
Over 180 to 300	+0.30	+0.45
	+0.20	+0.25
Over 300 to 500	+0.35	+0.55
	+0.23	+0.30

* Rubber covered seals using materials other than Nitrile may require different tolerances to be agreed upon between PEER and the end-user.



Lubrication

Lubrication is very important for the correct functioning of a seal. The sealing lip does not actually run on the shaft directly, but on an oil film, called meniscus. The thickness of this meniscus is usually between 1 to 3 μm , but is influenced by many factors, such as: oil viscosity, shaft surface finish and seal radial load.

The first few hours of new seal operation is called the *bedding-in* period. This is necessary not only for the meniscus to form, but also for the sealing edge to flatten. It is important to note that during this time limited leakage is possible.

Efficient lubrication of the sealing lip will ensure minimum wear and maximum life and seal efficiency. Oil seals must never be allowed to run dry! For this reason, both the seal and shaft must be greased or oiled prior to installation to assure sealing lip lubrication during the critical initial start-up of the application and *bedding-in* period of the seal.

Recommended Installation Methods



An installation tool should always be used when installing an oil seal. The use of a tool will make the installation easier and lower the possibility of seal cocking.

Remove any burrs, nicks or grooves from the bore and shaft. Sharp edges should be covered with a lubricated assembly sleeve or tape to protect the seal lip. Make sure that the shaft and bore dimensions match those for the seal being used. Make sure that the new seal faces in the same direction as the original one. Generally, the lip faces the lubricant that is being retained.

Before installation, wipe the seal lip and shaft with the lubricant that is being retained. The O.D. of a rubber covered seal should always be lubricated! This lubrication also helps the seal lip during initial run-in.

Select the correct installation tool. For best results, the center of the tool should be open so that pressure is applied only at the seals outer edge. Never hammer directly on the surface of the seal!

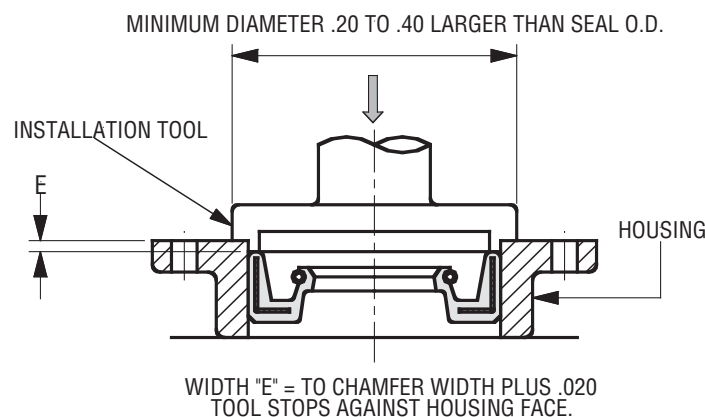
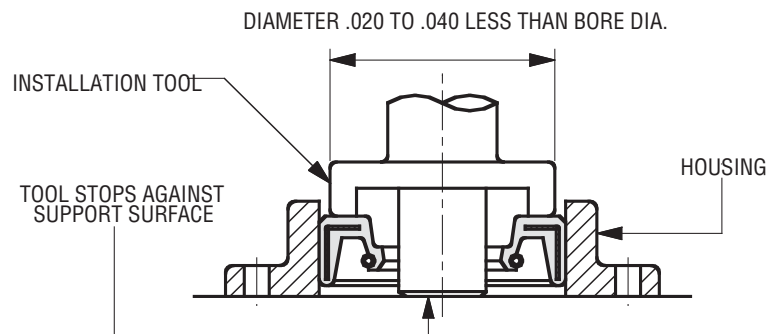



Recommended Installation Methods

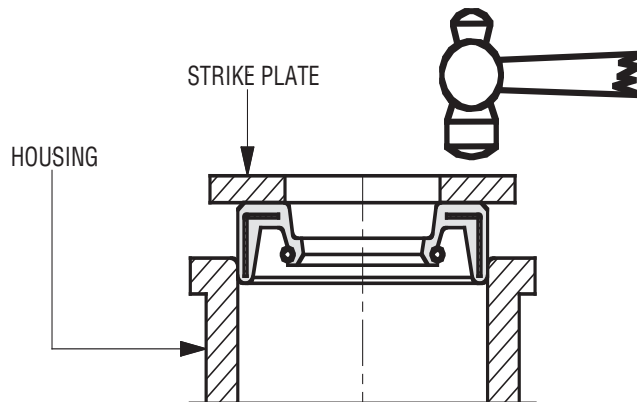
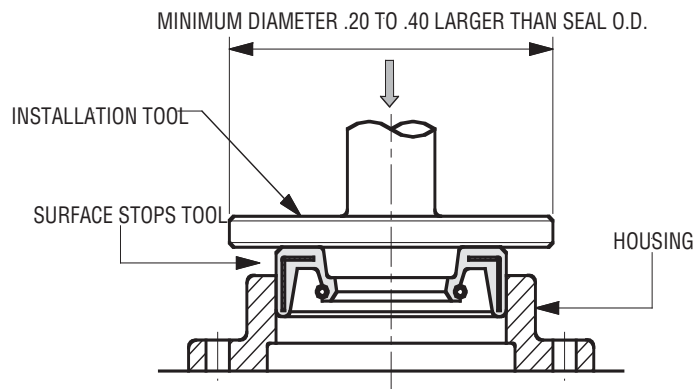



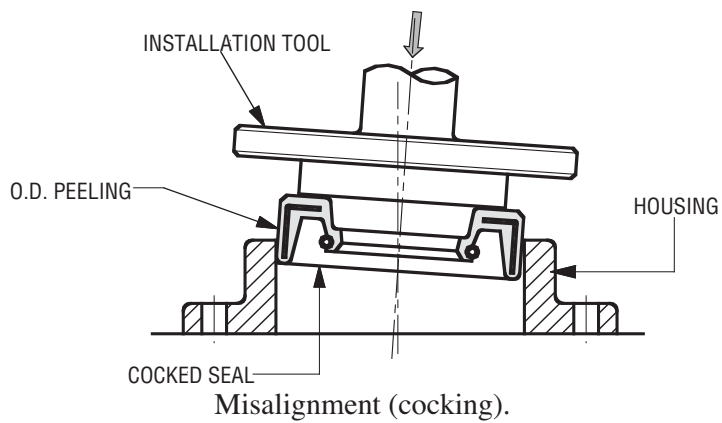
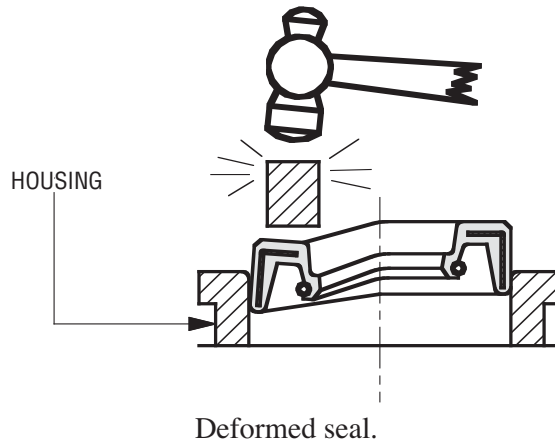
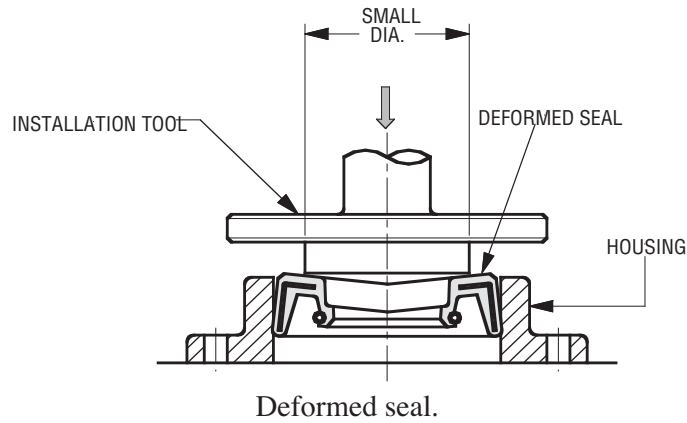

Improper Installation Methods



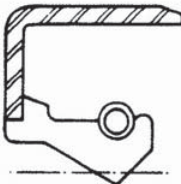
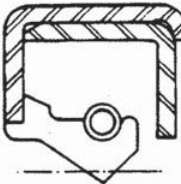
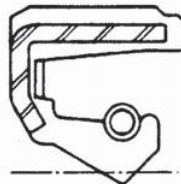
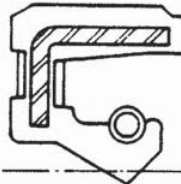
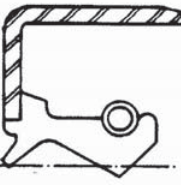
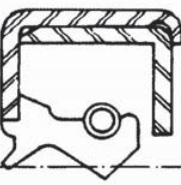
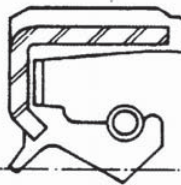
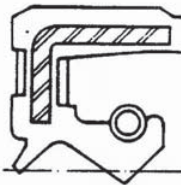

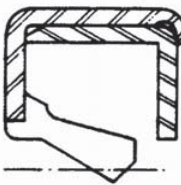
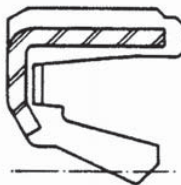
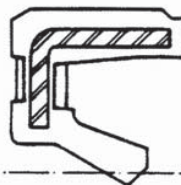
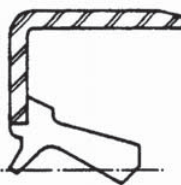
Standard Seal Designs

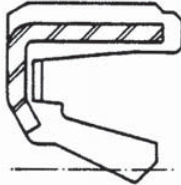
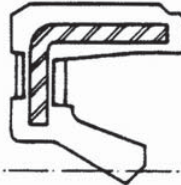
	Case Symbol	B	A	C	F
Lip Symbol	Description and Application	Metal O.D. with ground surface and front chamfer. Most common and economical.	Metal O.D. with an inner case for lip protection and greater structural rigidity.	Rubber covered O.D. for improved O.D. sealing ability. Preferred for soft alloy or plastic housings.	Rubber covered O.D. Similar to design C. Preferred where corrosion could be a problem.
S	Single lip with a garter spring. Seals in low pressure (up to 7psi). Not recommended in dirty environments.	 SB	 SA	 SC	 SF
T	Dual lip with a garter spring. Seals in low pressure (up to 7psi). Additional dust lip provides protection for the primary lip.	 TB	 TA	 TC	 TF
V	Single lip without a garter spring. Seals grease or viscous fluids in a non-pressure medium. Also used for dust and dirt exclusion.	 VB	 VA	 VC	 VF
K	Dual lip without a garter spring. As style V above. Additional dust lip provides protection for the primary lip.	 KB	 KA	 KC	 KF

Outer Case & Lip Designations



It is important to note that there are a number of seals listed in this catalog that do not match the lip and case styles noted on the previous page. Please refer to the following lists to help identify the designs that are not represented by a line drawing.

Lip Symbol

D = Double Lip, Double Spring Loaded
O = External Seal Type
U = Triple Lip

Case Symbol

H = Reverse Case Style
J = Special Flanged Indented Case
M = Fully Rubberized Inner Case
N = Short Flex High Pressure Design
S = Special Feature
Y = Design Variation from Standard
Z = Rubber Covered Chamfer

Other, more complex designs are available for special applications. Please contact PEER if further assistance is required.

Lip, Case & Spring Material Designations



Unless otherwise noted, all cases and springs for PEER seals are produced using carbon steel and all rubber coating and lips are produced using nitrile.

Lip Material

N = Nitrile
P = Polyacrylate
S = Silicone
T = PTFE
V = Fluoroelastomer

Case Material

C = Carbon Steel
S = Stainless Steel (304)

Spring Material

C = Carbon Steel
S = Stainless Steel (304)

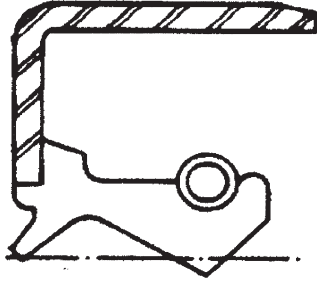

Engineering Information sheet

Customer & Division								
Address								
City/State/Zip								
Contact								
Telephone								
Customer P/N								
Type of Equipment								
Application								
<input type="checkbox"/> OEM	Date Required					Shaft Diameter _____	Shaft Chamfer & Angle _____	
<input type="checkbox"/> Aftermarket						Bore Diameter _____	Bore Chamfer & Angle _____	
Annual Usage	Peak Month Usage	Seal Width _____						
Shaft	<input type="checkbox"/> Horizontal <input type="checkbox"/> Vertical	Material	Finish	Hardness				
Bore	Material	Finish	Hardness	Installation Direction				
Motion	<input type="checkbox"/> Rotating	RPM	Normal Max	Direction from Air Side: <input type="checkbox"/> Clockwise <input type="checkbox"/> Counter-Clockwise <input type="checkbox"/> Bi-Rotational				
		Shaft Runout, TIR	Misalignment	Frequency of Rotation <input type="checkbox"/> Continuous <input type="checkbox"/> Intermittent				
	<input type="checkbox"/> Reciprocating	Stroke Length	Cycles/Min.	Special Operating Condition				
<input type="checkbox"/> Oscillating	Degrees of Arc	Cycles/Min.						
Fluid	Internal	Type	Level <input type="checkbox"/> Dry <input type="checkbox"/> Mist <input type="checkbox"/> Flooded					
	External	Type						
Temp.	<input type="checkbox"/> °C <input type="checkbox"/> °F	Minimum	Normal		Maximum			
Pressure	Normal PSI	Maximum PSI						
Bearing	<input type="checkbox"/> Radial	<input type="checkbox"/> Agricultural	<input type="checkbox"/> Bushing					
	<input type="checkbox"/> Other				<input type="checkbox"/> Tapered Roller			

Metric Conversion Chart



Fractions	Decimals	M.M.	Fractions	Decimals	M.M.	Fractions/Decimals/M.M.			Fractions/Decimals/M.M.					
1/64	0.004	0.10	37/64	0.578	14.68	1-15/32	1.469	37.31	2-7/8	2.874	73.00			
	0.010	0.25		0.591	15.00		1.496	38.00		2.875	73.03			
	0.016	0.40		19/32	0.594		15.08	1-1/2		1.500	38.10	2.913	74.00	
	0.020	0.50		39/64	0.609		15.48	1-17/32		1.531	38.89	2.938	74.61	
1/32	0.030	0.75	5/8	0.625	15.88	1-9/16	1.535	39.00	2-15/16	2.953	75.00			
	0.031	0.79	41/64	0.630	16.00		1.562	39.69		2.992	76.00			
	0.039	1.00		0.641	16.27		1.575	40.00		3	3.000	76.20		
	0.047	1.19		0.650	16.50		1-19/32	1.594		40.48	3.031	77.00		
0.059	1.50	21/32		0.656	16.67	1.614	41.00	3-1/16	3.062	77.79				
3/64	0.063	1.59	43/64	0.669	17.00	1-5/8	1.625	41.28	3-3/16	3.071	78.00			
	0.078	1.98		0.672	17.07		1.654	42.00		3.110	79.00			
	0.079	2.00		11/16	0.688		17.46	1-21/32		1.656	42.07	3-1/8	3.125	79.38
	0.094	2.38		45/64	0.703		17.86	1-11/16		1.688	42.86	3.150	80.00	
1/16	0.098	2.50	23/32	0.709	18.00	1-23/32	1.693	43.00	3-5/16	3.188	80.96			
	0.109	2.78		0.719	18.26		1.719	43.66		3.189	81.00			
	0.118	3.00		47/64	0.728		18.50	1.732		44.00	3.228	82.00		
	0.125	3.18			0.734		18.65	1-3/4		1.750	44.50	3-1/4	3.250	82.55
0.138	3.50	0.748	19.00		1.772	45.00	3.268	83.00						
0.141	3.57	3/4	0.750		19.05	1-25/32	1.781	45.24	3.307	84.00				
9/64	0.156	3.97	49/64	0.766	19.45	1-13/16	1.811	46.00	3-5/16	3.312	84.14			
	0.157	4.00	25/32	0.781	19.84		1.813	46.04		3.346	85.00			
	0.172	4.37	0.787	20.00	1-27/32		1.844	46.83		3-3/8	3.375	85.73		
	0.177	4.50	51/64	0.797	20.24		1.850	47.00		3.386	86.00			
3/16	0.188	4.76	13/16	0.813	20.64	1-7/8	1.875	47.63	3-7/16	3.425	87.00			
	0.197	5.00	0.827	21.00	1.890		48.00	3.438		87.31				
	0.203	5.16	53/64	0.828	21.03		1-29/32	1.906		48.42	3.465	88.00		
	0.217	5.50	27/32	0.844	21.43		1.929	49.00		3-1/2	3.500	88.90		
7/32	0.219	5.56	55/64	0.859	21.83	1-15/16	1.938	49.21	3-9/16	3.504	89.00			
	0.234	5.95	0.866	22.00	1.968		50.00	3.543		90.00				
	0.236	6.00	7/8	0.875	22.23		1-31/32	1.969		50.01	3.562	90.49		
	0.250	6.35	57/64	0.891	22.62		2	2.000		50.80	3.583	91.00		
17/64	0.256	6.50	29/32	0.906	23.00	2-1/16	2.008	51.00	3-5/8	3.622	92.00			
	0.266	6.75		0.906	23.02		2.047	52.00		3.625	92.08			
	0.276	7.00		59/64	0.922		23.42	2.062		52.39	3.661	93.00		
	0.281	7.14		15/16	0.938		23.81	2.087		53.00	3-11/16	3.688	93.66	
19/64	0.295	7.50	61/64	0.945	24.00	2-1/8	2.125	53.98	3-3/4	3.701	94.00			
	0.297	7.54		0.953	24.21		2.126	54.00		3.740	95.00			
	0.313	7.94		31/32	0.969		24.61	2.165		55.00	3.750	95.25		
	0.315	8.00		0.984	25.00		2-3/16	2.188		55.56	3.780	96.00		
5/16	0.328	8.33	1	1.000	25.40	2-3/8	2.205	56.00	3-13/16	3.813	96.84			
	0.335	8.50	1.024	26.00	2.244		57.00	3.819		97.00				
	0.344	8.73	1-1/32	1.031	26.19		2-1/4	2.250		57.15	3.858	98.00		
	0.354	9.00	1-1/16	1.062	26.99		2.283	58.00		3-7/8	3.875	98.43		
23/64	0.359	9.13	1-3/32	1.063	27.00	2-5/16	2.312	58.74	4-1/16	3.898	99.00			
	0.374	9.50		1.094	27.78		2.323	59.00		3.937	100.00			
	0.375	9.53		1.102	28.00		2.362	60.00		3-15/16	3.938	100.01		
	0.391	9.92		1-1/8	1.125		28.58	2-3/8		2.375	60.33	3.976	101.00	
13/32	0.394	10.00	1-5/32	1.142	29.00	2-7/16	2.402	61.00	4	4.000	101.60			
	0.406	10.32		1.156	29.37		2.438	61.91		4-1/16	4.062	103.19		
	0.413	10.50		1.181	30.00		2.441	62.00		4-1/8	4.125	104.78		
	0.422	10.72		1-3/16	1.188		30.16	2.480		63.00	4-3/16	4.134	105.00	
7/16	0.433	11.00	1-7/32	1.219	30.96	2-1/2	2.500	63.50	4-1/4	4.188	106.36			
	0.438	11.11	1.221	31.00	2.520		64.00	4.250		107.95				
	0.453	11.51	1-1/4	1.250	31.75		2.559	65.00		4-5/16	4.312	109.54		
	0.469	11.91	1.260	32.00	2-9/16		2.562	65.09		4.331	110.00			
31/64	0.472	12.00	1-9/32	1.281	32.54	2-5/8	2.598	66.00	4-3/8	4.375	111.13			
	0.484	12.30	1.299	33.00	2.625		66.68	4-7/16		4.438	112.71			
	0.492	12.50	1-5/16	1.312	33.34		2.638	67.00		4-1/2	4.500	114.30		
	0.500	12.70	1.339	34.00	2.677		68.00	4.528		115.00				
1/2	0.512	13.00	1-11/32	1.344	34.13	2-11/16	2.688	68.26	4-9/16	4.562	115.89			
	0.516	13.10	1-3/8	1.375	34.93		2.717	69.00		4-5/8	4.625	117.48		
	0.531	13.50	1.378	35.00	2-3/4		2.750	69.85		4.724	120.00			
	0.547	13.89	1-13/32	1.406	35.72		2.756	70.00		4-3/4	4.750	120.65		
9/16	0.551	14.00	1-7/16	1.417	36.00	2-13/16	2.795	71.00	4-7/8	4.875	123.83			
	0.563	14.29		1.438	36.51		2.813	71.44		4.921	125.00			
	0.571	14.50		1.457	37.00		2.835	72.00		5	5.000	127.00		



A Complete Listing of PEER Shaft Seals

The following pages show a complete listing of seals that are already manufactured or can be manufactured by PEER. Please note that the range of sizes and styles of seals available from PEER is not limited to those listed in this catalog. PEER has the capability to produce seals of many different sizes and styles. Special types of seals can also be produced, according to your specific requirements. Please contact PEER directly for further assistance if you need help with a seal that is not listed in this catalog.

The following section contains a listing of inch size seals immediately followed by a listing of metric sizes. After the product listing is a complete interchange for the inch sizes followed by the metric sizes.

It is important to note that all seals manufactured by PEER begin with the prefix "POS" which stands for "PEER Oil Seals". The "POS" signifies that the seal has been manufactured according to the exacting standards of PEER Bearing Company.

Inch seals have a part number that is directly related to the critical dimensions of the seal. For example, the POS22530037TB-S is made for a 2.25" (2-1/4") shaft, to fit into approximately a 3" housing bore, and is approximately .37" (3/8") wide. The "TB" signifies a double lip seal with a garter spring and a single case configuration. The "-S" signifies that this particular seal has an O.D. sealant on the outer case of the seal. Please note that exact dimensions of the seal, including the remainder of the decimal dimensions, can be found listed in this catalog.

Metric seals have a part number that is very simple to understand. For example, the POS40567TC is made for a 40mm shaft, 56mm housing bore, and 7mm width. The "TC" signifies a double lip seal with a garter spring and a single case with a rubber covered O.D.

Inch Parts Listing - Shaft Seals



All PEER Part #'s prefixed with "POS"

PEER Part #	Shaft	Bore	Width	Lip Mat.	PEER Part #	Shaft	Bore	Width	Lip Mat.
0186225VC	0.187	0.628	0.250	Nitrile	0621525TB-S	0.625	1.561	0.250	Nitrile
0257525SC-SS	0.250	0.750	0.250	Nitrile	0651125SB	0.656	1.124	0.250	Nitrile
0319937TB	0.312	0.999	0.375	Nitrile	0651225SB-S	0.656	1.250	0.250	Nitrile
0375609VB	0.375	0.562	0.094	Nitrile	0651331SB	0.656	1.375	0.313	Nitrile
0376815VB-S	0.375	0.687	0.156	Nitrile	0651525SB	0.656	1.575	0.250	Nitrile
0377525TB	0.375	0.750	0.250	Nitrile	0660918SB	0.669	0.999	0.188	Nitrile
0378725SC	0.375	0.875	0.250	Nitrile	0661131TC	0.669	1.125	0.312	Nitrile
0378725TB	0.375	0.875	0.250	Nitrile	0661131TF	0.669	1.125	0.312	Nitrile
0379925TB	0.375	0.999	0.250	Nitrile	06871625TB	0.687	1.624	0.250	Nitrile
0438318VB	0.438	0.836	0.188	Nitrile	06811225SB	0.688	1.124	0.250	Nitrile
0438725SM	0.438	0.875	0.250	Nitrile	0681118SB	0.688	1.188	0.188	Nitrile
0439937SB	0.438	0.999	0.375	Nitrile	0681231SB	0.688	1.250	0.313	Nitrile
0507512VB-S	0.500	0.750	0.125	Nitrile	0681425SB	0.688	1.499	0.250	Nitrile
0508712VM	0.500	0.875	0.125	Nitrile	0711237TB	0.718	1.250	0.375	Nitrile
0508725VB	0.500	0.875	0.250	Nitrile	0750912VM	0.750	0.999	0.125	Nitrile
0509925TB	0.500	0.999	0.250	Nitrile	0751115VM	0.750	1.124	0.156	Nitrile
0509925TB-S	0.500	0.999	0.250	Nitrile	0751118SB	0.750	1.124	0.188	Nitrile
0501025TC	0.500	1.000	0.250	Nitrile	0751118SB-S	0.750	1.124	0.188	Nitrile
0501037SZ-V	0.500	1.000	0.375	Viton	0751118SB-CSV-S	0.750	1.124	0.188	Viton
0501125TB	0.500	1.124	0.250	Nitrile	0751225SB	0.750	1.250	0.250	Nitrile
0501125TC	0.500	1.125	0.250	Nitrile	0751225TB	0.750	1.250	0.250	Nitrile
0501131TBW-SS	0.500	1.125	0.312	Nitrile	0751225TB-CSV	0.750	1.250	0.250	Viton
0501225TB	0.500	1.250	0.250	Nitrile	0751225TC	0.750	1.250	0.250	Nitrile
0501325TB	0.500	1.375	0.250	Nitrile	0751225TF	0.750	1.250	0.250	Nitrile
0531131TB	0.531	1.124	0.312	Nitrile	07513125SB	0.750	1.312	0.250	Nitrile
0561025TB-S	0.562	1.000	0.250	Nitrile	0751325SB-S	0.750	1.375	0.250	Nitrile
0561225TB	0.562	1.250	0.250	Nitrile	0751325TB-S	0.750	1.375	0.250	Nitrile
0561325TB	0.562	1.375	0.250	Nitrile	0751325TB-CSV	0.750	1.375	0.250	Viton
0569925SB	0.563	0.999	0.250	Nitrile	0751325TC-P	0.750	1.375	0.250	Polycrylate
0561125TB	0.563	1.124	0.250	Nitrile	0751325TC-SS	0.750	1.375	0.250	Nitrile
0591131TB	0.593	1.124	0.312	Nitrile	0751425SB	0.750	1.499	0.250	Nitrile
0591231TB	0.593	1.250	0.312	Nitrile	0751425TB-S	0.750	1.499	0.250	Nitrile
0591331TB-S	0.593	1.375	0.312	Nitrile	0751625TB	0.750	1.624	0.250	Nitrile
0591125VB	0.594	1.124	0.250	Nitrile	0751725TB	0.750	1.752	0.250	Nitrile
0628109VM	0.625	0.812	0.094	Nitrile	07517825TB	0.750	1.783	0.250	Nitrile
0628112VM-SC	0.625	0.812	0.125	Nitrile	0751825TB	0.750	1.874	0.250	Nitrile
0629925TB-S	0.625	0.999	0.250	Nitrile	0752031TB	0.750	2.047	0.312	Nitrile
0621125TB	0.625	1.124	0.250	Nitrile	0781225TB	0.781	1.250	0.250	Nitrile
0621125TB-V	0.625	1.124	0.250	Viton	0781331SB	0.781	1.375	0.313	Nitrile
0621131SZ-SSV	0.625	1.125	0.312	Viton	0781431SB	0.781	1.499	0.313	Nitrile
0621131TF	0.625	1.125	0.312	Nitrile	0781625SB-S	0.781	1.624	0.250	Nitrile
0621225TB	0.625	1.250	0.250	Nitrile	0781631TB	0.781	1.624	0.313	Nitrile
0621237SA-S	0.625	1.250	0.375	Nitrile	0781825TB	0.781	1.828	0.250	Nitrile
0621325TB	0.625	1.375	0.250	Nitrile	07871118SB-S	0.787	1.124	0.188	Nitrile
0621325TB-V	0.625	1.375	0.250	Viton	0811225TB	0.812	1.250	0.250	Nitrile
0621325VB-S	0.625	1.375	0.250	Nitrile	0811325SB	0.812	1.312	0.250	Nitrile
0621331TB-SS	0.625	1.375	0.312	Nitrile	0811331TB	0.812	1.375	0.312	Nitrile
0621425TB	0.625	1.499	0.250	Nitrile	0811537SA	0.812	1.575	0.375	Nitrile



Inch Parts Listing - Shaft Seals

All PEER Part #'s prefixed with "POS"

PEER Part #	Shaft	Bore	Width	Lip Mat.	PEER Part #	Shaft	Bore	Width	Lip Mat.
0811625TB-CSV	0.812	1.624	0.250	Viton	1001725TB-S	1.000	1.752	0.250	Nitrile
0812437TB	0.812	2.441	0.375	Nitrile	1001725TB-V	1.000	1.752	0.250	Viton
0841331TB	0.843	1.374	0.312	Nitrile	10017846VA5	1.000	1.780	0.468	Nitrile
0841831TB	0.843	1.828	0.312	Nitrile	10017825VH	1.000	1.781	0.250	Nitrile
0862025TB	0.866	2.047	0.250	Nitrile	10017846VB-S	1.000	1.781	0.469	Nitrile
0871112VB	0.875	1.125	0.125	Nitrile	10017846VHY-S	1.000	1.781	0.469	Nitrile
0871218SB	0.875	1.250	0.188	Nitrile	1001825TB	1.000	1.828	0.250	Nitrile
0871218TB	0.875	1.250	0.188	Nitrile	1001825TB-CS	1.000	1.828	0.250	Nitrile
0871325TB	0.875	1.375	0.250	Nitrile	1001825TC	1.000	1.828	0.250	Nitrile
0871325TB-V	0.875	1.375	0.250	Viton	1001825TC-CS	1.000	1.828	0.250	Nitrile
0871331TA	0.875	1.375	0.312	Nitrile	10018725TB	1.000	1.874	0.250	Nitrile
0871425TB-S	0.875	1.499	0.250	Nitrile	1001937TC	1.000	1.980	0.375	Nitrile
0871425TB-CSV-S	0.875	1.499	0.250	Viton	1001931TB-S	1.000	1.983	0.313	Nitrile
0871431SB	0.875	1.499	0.313	Nitrile	1002025SB-CSV-S	1.000	2.000	0.250	Viton
0871625TB	0.875	1.624	0.250	Nitrile	1002025TB	1.000	2.000	0.250	Nitrile
0871725TB	0.875	1.752	0.250	Nitrile	1002025TB-V	1.000	2.000	0.250	Viton
0871837TB	0.875	1.828	0.375	Nitrile	1002025VH-S	1.000	2.000	0.250	Nitrile
0871825TB	0.875	1.874	0.250	Nitrile	10020425TB	1.000	2.047	0.250	Nitrile
0901439TB	0.906	1.499	0.390	Nitrile	10020431TB-S	1.000	2.047	0.312	Nitrile
0931425TB	0.937	1.499	0.250	Nitrile	10020625TB-S	1.000	2.062	0.250	Nitrile
0931425TB-CSV	0.937	1.499	0.250	Viton	1002327OUB	1.000	2.356	0.270	Nitrile
0931625TB	0.937	1.624	0.250	Nitrile	1002437TB	1.000	2.441	0.375	Nitrile
0931725TB	0.937	1.752	0.250	Nitrile	1061631TM	1.062	1.686	0.313	Nitrile
0931843SA	0.937	1.828	0.437	Nitrile	1061634TB-T	1.062	1.686	0.375	Teflon
0961431SA	0.968	1.499	0.312	Nitrile	1061731TB-S	1.062	1.752	0.312	Nitrile
0961625TB	0.968	1.624	0.250	Nitrile	1061837TB-S	1.062	1.828	0.375	Nitrile
0961725TB	0.968	1.752	0.250	Nitrile	10618725TB-S	1.062	1.874	0.250	Nitrile
0961843SA	0.968	1.828	0.437	Nitrile	1061943SA-S	1.062	1.983	0.437	Nitrile
0981425TB	0.984	1.499	0.250	Nitrile	1062025TB-S	1.062	2.000	0.250	Nitrile
0981425TB-V	0.984	1.499	0.250	Viton	1062043SB	1.062	2.000	0.437	Nitrile
0981737TM-SS	0.984	1.749	0.375	Nitrile	1062037TB-S	1.062	2.062	0.375	Nitrile
0981737TM-SSV	0.984	1.749	0.375	Viton	10632025SB-S	1.063	2.000	0.250	Nitrile
09852040TA-S	0.985	2.000	0.406	Nitrile	1121418VB-S	1.125	1.499	0.188	Nitrile
10013112VB	1.000	1.312	0.125	Nitrile	1121525TB-P	1.125	1.561	0.250	Polyacrylate
1001318VM	1.000	1.375	0.189	Nitrile	1121625TB	1.125	1.624	0.250	Nitrile
1001423SC-CS	1.000	1.437	0.236	Nitrile	1121625TB-CSV	1.125	1.624	0.250	Viton
10014325TB-S	1.000	1.437	0.250	Nitrile	11217525TB-S	1.125	1.752	0.250	Nitrile
10014325TB-V	1.000	1.437	0.250	Viton	1121725VH	1.125	1.781	0.250	Nitrile
1001425SB	1.000	1.499	0.250	Nitrile	1121740TC	1.125	1.781	0.406	Nitrile
1001425TB	1.000	1.499	0.250	Nitrile	1121746VHY	1.125	1.781	0.469	Nitrile
1001425TB-V	1.000	1.499	0.250	Viton	11218225TB-S	1.125	1.828	0.250	Nitrile
1001431TB	1.000	1.499	0.312	Nitrile	11218531SA-S	1.125	1.852	0.313	Nitrile
1001525TB-S	1.000	1.561	0.250	Nitrile	1121825SB-SSV	1.125	1.874	0.250	Viton
1001518VM	1.000	1.563	0.187	Nitrile	1121825SB-V	1.125	1.874	0.250	Viton
10015725TB	1.000	1.575	0.250	Nitrile	1121825TB-S	1.125	1.874	0.250	Nitrile
1001625TB-S	1.000	1.624	0.250	Nitrile	11219334VB	1.125	1.938	0.343	Nitrile
1001625TB-CSV	1.000	1.624	0.250	Viton	1121925TB-S	1.125	1.983	0.250	Nitrile
10016825TB-S	1.000	1.686	0.250	Nitrile	1122025TB	1.125	2.000	0.250	Nitrile

Inch Parts Listing – Shaft Seals



All PEER Part #'s prefixed with "POS"

PEER Part #	Shaft	Bore	Width	Lip Mat.	PEER Part #	Shaft	Bore	Width	Lip Mat.
1122025TB-V	1.125	2.000	0.250	Viton	1252125TB-S	1.250	2.125	0.250	Nitrile
1122037TB-S	1.125	2.000	0.375	Nitrile	1252225TC	1.250	2.240	0.250	Nitrile
1122040TA-S	1.125	2.000	0.406	Nitrile	12522525SB	1.250	2.250	0.250	Nitrile
11220431TB-S	1.125	2.047	0.312	Nitrile	12522525VB	1.250	2.250	0.250	Nitrile
11220625TB-S	1.125	2.062	0.250	Nitrile	12522550TB-S	1.250	2.250	0.500	Nitrile
1122131SB	1.125	2.125	0.250	Nitrile	1252337TB-S	1.250	2.374	0.313	Nitrile
1122250SA-S	1.125	2.250	0.500	Nitrile	12523731TC	1.250	2.375	0.313	Nitrile
1122425TB-S	1.125	2.441	0.250	Nitrile	1252437TB-S	1.250	2.437	0.375	Nitrile
1151625TB	1.156	1.686	0.250	Nitrile	12524437TB	1.250	2.441	0.375	Nitrile
1151825SB-S	1.156	1.874	0.250	Nitrile	12524437TC	1.250	2.441	0.375	Nitrile
1152025TB-S	1.156	2.000	0.250	Nitrile	1252537TB-S	1.250	2.502	0.375	Nitrile
1152037TB-S	1.156	2.062	0.375	Nitrile	1292031TM	1.291	2.000	0.313	Nitrile
1181837TB-S	1.187	1.828	0.375	Nitrile	1292034TB-T	1.291	2.000	0.340	Teflon
1182043TB-SS	1.187	2.000	0.437	Nitrile	1311837TB-S	1.312	1.874	0.375	Nitrile
1182025TB-S	1.187	2.062	0.250	Nitrile	1312031TB-S	1.312	2.000	0.312	Nitrile
1182125TB-S	1.187	2.125	0.250	Nitrile	1312131TB-S	1.312	2.125	0.312	Nitrile
1182225TB-S	1.187	2.250	0.250	Nitrile	1312231TB-S	1.312	2.250	0.312	Nitrile
1182425TB-S	1.187	2.437	0.250	Nitrile	13132031TB-S	1.313	2.062	0.313	Nitrile
11824425TB-S	1.187	2.441	0.250	Nitrile	13721943TM	1.372	1.979	0.432	Nitrile
11882025SB	1.188	2.000	0.250	Nitrile	1371725SM-CS-S	1.375	1.750	0.250	Nitrile
1211940VB-S	1.219	1.979	0.406	Nitrile	13718231SB-S	1.375	1.828	0.313	Nitrile
12516218SB-S	1.250	1.625	0.188	Nitrile	1371825TB	1.375	1.874	0.250	Nitrile
12516825TB-S	1.250	1.686	0.250	Nitrile	1371831TB-SS-S	1.375	1.874	0.313	Nitrile
12516825TB-V	1.250	1.686	0.250	Viton	1371831TF-SS	1.375	1.874	0.313	Nitrile
1251631TC	1.250	1.687	0.313	Nitrile	1371931SB-CSP-S	1.375	1.983	0.313	Polyacrylate
1251725TB-S	1.250	1.752	0.250	Nitrile	1372031SB	1.375	2.000	0.313	Nitrile
1251725TB-CSV	1.250	1.752	0.250	Viton	1372031TB	1.375	2.000	0.313	Nitrile
1251731TC	1.250	1.752	0.312	Nitrile	1372031TB-V	1.375	2.000	0.313	Viton
1251825TB-S	1.250	1.874	0.250	Nitrile	13721031TB	1.375	2.106	0.313	Nitrile
1251925TB	1.250	1.979	0.250	Nitrile	1372131TB-S	1.375	2.125	0.313	Nitrile
1251925TB-S	1.250	1.979	0.250	Nitrile	1372137SC	1.375	2.125	0.375	Nitrile
1251925TB-V	1.250	1.979	0.250	Viton	1372231TB-S	1.375	2.250	0.312	Nitrile
1251925VA5	1.250	1.979	0.250	Nitrile	1372331TB-S	1.375	2.374	0.312	Nitrile
1251925VB	1.250	1.979	0.250	Nitrile	1372431TB-S	1.375	2.441	0.313	Nitrile
1251925VH-S	1.250	1.979	0.250	Nitrile	1372537TB	1.375	2.502	0.375	Nitrile
1251940VA5	1.250	1.979	0.406	Nitrile	13725637TB-S	1.375	2.562	0.375	Nitrile
1251940VHY	1.250	1.979	0.406	Nitrile	1372637TB-S	1.375	2.623	0.375	Nitrile
12519825TB	1.250	1.983	0.250	Nitrile	1372746SA-S	1.375	2.716	0.468	Nitrile
12519825TB-CSV	1.250	1.983	0.250	Viton	1372831TB-S	1.375	2.835	0.313	Nitrile
12519825VH	1.250	1.983	0.250	Nitrile	1372846TB-S	1.375	2.875	0.468	Nitrile
1252025TB	1.250	2.000	0.250	Nitrile	1432131TB	1.438	2.125	0.313	Nitrile
1252025TB-S	1.250	2.000	0.250	Nitrile	1432231TB	1.438	2.250	0.313	Nitrile
1252025TB-CSV	1.250	2.000	0.250	Viton	1432331TB	1.438	2.374	0.313	Nitrile
1252031TC	1.250	2.000	0.312	Nitrile	1501918VB	1.500	1.983	0.188	Nitrile
1252031TF	1.250	2.000	0.313	Nitrile	1501925TB	1.500	1.983	0.250	Nitrile
1252043TB-CSV	1.250	2.000	0.437	Viton	15019825KB	1.500	1.989	0.250	Nitrile
1252037TB-S	1.250	2.047	0.375	Nitrile	1502031SB-S	1.500	2.000	0.313	Nitrile
12520625TB-S	1.250	2.062	0.250	Nitrile	15020437TB-S	1.500	2.048	0.375	Nitrile



Inch Parts Listing - Shaft Seals

All PEER Part #'s prefixed with "POS"

PEER Part #	Shaft	Bore	Width	Lip Mat.	PEER Part #	Shaft	Bore	Width	Lip Mat.
15020631SB-S	1.500	2.062	0.313	Nitrile	1622525VH	1.625	2.562	0.250	Nitrile
15020631SB-V-S	1.500	2.062	0.313	Viton	1622543UB	1.625	2.562	0.250	Nitrile
15020631TB-S	1.500	2.062	0.313	Nitrile	16225631TB-V-S	1.625	2.562	0.313	Viton
15020631TB-V-S	1.500	2.062	0.313	Viton	1622543VHY	1.625	2.562	0.438	Nitrile
15020637SB-S	1.500	2.062	0.375	Nitrile	1622631TB	1.625	2.623	0.313	Nitrile
1502131TB	1.500	2.125	0.312	Nitrile	1622637SC	1.625	2.625	0.375	Nitrile
1502131SB-S	1.500	2.125	0.313	Nitrile	16226837SB	1.625	2.686	0.375	Nitrile
1502231TB	1.500	2.250	0.313	Nitrile	1622725SB	1.625	2.750	0.250	Nitrile
1502231TB-CSV	1.500	2.250	0.313	Viton	1622725VB	1.625	2.750	0.250	Nitrile
15022270UB	1.500	2.286	0.270	Nitrile	1622725TB	1.625	2.750	0.312	Nitrile
15022420UAS	1.500	2.286	0.420	Nitrile	1623031TA	1.625	3.000	0.312	Nitrile
1502339VHY	1.500	2.328	0.390	Nitrile	1682431TB	1.687	2.437	0.312	Nitrile
1502340VB	1.500	2.328	0.406	Nitrile	1682531TB	1.687	2.502	0.312	Nitrile
1502350TB	1.500	2.328	0.500	Nitrile	1682550TB	1.687	2.561	0.500	Nitrile
1502325VH	1.500	2.374	0.250	Nitrile	1682731TB	1.687	2.750	0.312	Nitrile
1502331SB-S	1.500	2.374	0.313	Nitrile	1682331TB	1.688	2.328	0.313	Nitrile
1502331TB-S	1.500	2.374	0.313	Nitrile	17182550VB	1.718	2.561	0.500	Nitrile
1502331TB-V	1.500	2.375	0.312	Viton	1712550TB	1.719	2.561	0.500	Nitrile
1502337SM	1.500	2.375	0.375	Nitrile	1712550TB-V	1.719	2.561	0.500	Viton
1502437TB-S	1.500	2.437	0.375	Nitrile	1712550VB	1.719	2.561	0.500	Nitrile
1502431SB	1.500	2.441	0.313	Nitrile	17125650VHY	1.719	2.562	0.500	Nitrile
1502446SA	1.500	2.441	0.469	Nitrile	1752118SB-S	1.750	2.125	0.188	Nitrile
1502531TB-S	1.500	2.502	0.312	Nitrile	1752231SA	1.750	2.250	0.313	Nitrile
15025650TA	1.500	2.561	0.500	Nitrile	1752331VB	1.750	2.328	0.312	Nitrile
1502625VH	1.500	2.623	0.250	Nitrile	1752350TC	1.750	2.356	0.500	Nitrile
1502650TB-P	1.500	2.686	0.500	Polyacrylate	1752331TB-V	1.750	2.374	0.312	Viton
1502743SB-S	1.500	2.716	0.438	Nitrile	1752331TB-S	1.750	2.374	0.313	Nitrile
1502746SA-S	1.500	2.716	0.468	Nitrile	1752431TB-S	1.750	2.437	0.312	Nitrile
15027531TB-S	1.500	2.750	0.312	Nitrile	1752431TB-CSV-S	1.750	2.437	0.313	Viton
1502846SA-S	1.500	2.875	0.468	Nitrile	1752446VHY	1.750	2.441	0.469	Nitrile
1562137TB	1.562	2.125	0.375	Nitrile	1752531TB-S	1.750	2.502	0.313	Nitrile
1562437TB	1.562	2.437	0.375	Nitrile	1752531TB-CSV	1.750	2.502	0.313	Viton
1562637TB	1.562	2.686	0.375	Nitrile	1752525VH	1.750	2.561	0.250	Nitrile
1562837TB	1.562	2.875	0.375	Nitrile	17525631TB	1.750	2.561	0.312	Nitrile
1592446SA	1.593	2.437	0.468	Nitrile	17525631SB-S	1.750	2.561	0.313	Nitrile
1592525SB	1.593	2.502	0.250	Nitrile	1752550SA-S	1.750	2.561	0.500	Nitrile
1622025TB	1.625	2.000	0.250	Nitrile	17525650TB-S	1.750	2.561	0.500	Nitrile
1622131TB	1.625	2.116	0.312	Nitrile	1752629UA	1.750	2.623	0.290	Nitrile
1621225SB-S	1.625	2.125	0.250	Nitrile	1752631TB-S	1.750	2.623	0.312	Nitrile
1622231TB	1.625	2.250	0.312	Nitrile	17526290UA	1.750	2.630	0.290	Nitrile
16223243VHY	1.625	2.328	0.438	Nitrile	17526837TB	1.750	2.686	0.375	Nitrile
1622331TB	1.625	2.374	0.313	Nitrile	1752725VH-S	1.750	2.716	0.250	Nitrile
1622431TB-S	1.625	2.437	0.313	Nitrile	1752735UB	1.750	2.718	0.359	Nitrile
1622431TB-CSV-S	1.625	2.437	0.313	Viton	1752735VHY	1.750	2.718	0.359	Nitrile
16224431TB	1.625	2.441	0.313	Nitrile	17527531TB	1.750	2.750	0.313	Nitrile
16225025VH-S	1.625	2.502	0.250	Nitrile	17527537TB	1.750	2.758	0.375	Nitrile
1622531TB	1.625	2.502	0.313	Nitrile	1752825VH-S	1.750	2.875	0.250	Nitrile
1622531TB-P	1.625	2.502	0.313	Polyacrylate	1752831SB-S	1.750	2.875	0.313	Nitrile

Inch Parts Listing – Shaft Seals



All PEER Part #'s prefixed with "POS"

PEER Part #	Shaft	Bore	Width	Lip Mat.	PEER Part #	Shaft	Bore	Width	Lip Mat.
1752837TB	1.750	2.875	0.375	Nitrile	2002837TA-S	2.000	2.875	0.375	Nitrile
1752937TB	1.750	2.996	0.375	Nitrile	20028837TB	2.000	2.880	0.375	Nitrile
1752931TC	1.750	2.997	0.313	Nitrile	2003031TB	2.000	3.000	0.312	Nitrile
1753037SC	1.750	3.000	0.375	Nitrile	2003050SA-S	2.000	3.000	0.500	Nitrile
1753037TB-S	1.750	3.000	0.375	Nitrile	2003025VH	2.000	3.061	0.250	Nitrile
17530637TB	1.750	3.061	0.375	Nitrile	20030637TB-S	2.000	3.062	0.375	Nitrile
1753131SB	1.750	3.189	0.313	Nitrile	20031231TB-S	2.000	3.125	0.312	Nitrile
1753550SA	1.750	3.543	0.500	Nitrile	20031237SB-S	2.000	3.125	0.375	Nitrile
1812446SA	1.812	2.437	0.468	Nitrile	2003137TA	2.000	3.150	0.375	Nitrile
1812637TB	1.812	2.686	0.375	Nitrile	2003243TA-S	2.000	3.251	0.437	Nitrile
1812737TB	1.812	2.750	0.375	Nitrile	2003343TA	2.000	3.371	0.438	Nitrile
1812837SB-S	1.813	2.875	0.313	Nitrile	2003543SA	2.000	3.543	0.438	Nitrile
1812837TB	1.812	2.875	0.375	Nitrile	2003625VH	2.000	3.623	0.250	Nitrile
1872325SC	1.875	2.397	0.250	Nitrile	2003643SA-S	2.000	3.623	0.438	Nitrile
1872531TB	1.875	2.502	0.312	Nitrile	2032856TC	2.031	2.880	0.563	Nitrile
1872531SB	1.875	2.502	0.313	Nitrile	2062843SA	2.062	2.875	0.437	Nitrile
1872546TBJ-CSP	1.875	2.561	0.469	Polyacrylate	2063037TB	2.062	3.000	0.375	Nitrile
1872631TB	1.875	2.623	0.313	Nitrile	20631843SC	2.062	3.187	0.437	Nitrile
18726837TB	1.875	2.686	0.375	Nitrile	2063143TA	2.062	3.190	0.437	Nitrile
1872731TB	1.875	2.750	0.313	Nitrile	2092735VHY	2.094	2.718	0.359	Nitrile
18727843TA	1.875	2.782	0.438	Nitrile	2122737TB	2.125	2.750	0.375	Nitrile
18728337TB-S	1.875	2.835	0.375	Nitrile	2122843TB	2.125	2.875	0.438	Nitrile
1872831TB	1.875	2.875	0.313	Nitrile	2123037TA	2.125	3.000	0.375	Nitrile
1873025UB	1.875	3.000	0.250	Nitrile	2123050TB	2.125	3.000	0.500	Nitrile
1873025VH	1.875	3.000	0.250	Nitrile	21230625VH-S	2.125	3.061	0.250	Nitrile
1873031TB	1.875	3.000	0.312	Nitrile	21230650TA	2.125	3.061	0.500	Nitrile
1873050VB	1.875	3.000	0.500	Nitrile	2123137TB	2.125	3.125	0.375	Nitrile
18730631TB	1.875	3.061	0.313	Nitrile	21231837TB	2.125	3.189	0.375	Nitrile
1873131TB	1.875	3.125	0.313	Nitrile	2123250TB	2.125	3.264	0.500	Nitrile
1873137SB-S	1.875	3.125	0.375	Nitrile	21233537TA	2.125	3.350	0.375	Nitrile
1873137TB	1.875	3.189	0.375	Nitrile	21233737TA	2.125	3.371	0.375	Nitrile
1932446TB	1.937	2.412	0.468	Nitrile	2123337VB	2.125	3.372	0.375	Nitrile
19324325TB	1.937	2.437	0.250	Nitrile	2123343TB	2.125	3.372	0.438	Nitrile
1932531SB	1.937	2.562	0.317	Nitrile	2123537TA	2.125	3.500	0.375	Nitrile
1932631TB	1.937	2.623	0.312	Nitrile	21235450TA	2.125	3.543	0.500	Nitrile
1932731TB	1.937	2.750	0.312	Nitrile	2163237TC	2.165	3.250	0.375	Nitrile
1932831TB	1.937	2.875	0.312	Nitrile	2182837TB	2.187	2.875	0.375	Nitrile
1932937TB	1.937	2.996	0.375	Nitrile	2183037TB	2.187	3.000	0.375	Nitrile
19330637TB-S	1.937	3.061	0.375	Nitrile	2183143TB	2.187	3.189	0.437	Nitrile
1933137TB	1.937	3.189	0.375	Nitrile	2183337TA	2.187	3.350	0.375	Nitrile
1933537TA	1.937	3.543	0.375	Nitrile	21833737TA	2.187	3.371	0.375	Nitrile
19382528VB	1.938	2.506	0.281	Nitrile	2252856TB	2.250	2.890	0.562	Nitrile
1943037UB-S	1.945	3.063	0.375	Nitrile	2252943TA	2.250	2.997	0.438	Nitrile
2002525TC	2.000	2.502	0.250	Nitrile	22530025SA	2.250	3.000	0.250	Nitrile
20026837TB	2.000	2.686	0.375	Nitrile	22530037TB-S	2.250	3.000	0.375	Nitrile
20027137TB	2.000	2.716	0.375	Nitrile	2253025VH	2.250	3.061	0.250	Nitrile
2002731TB	2.000	2.750	0.313	Nitrile	2253025VHY	2.250	3.061	0.250	Nitrile
2002831SB	2.000	2.875	0.313	Nitrile	2253037TB	2.250	3.061	0.375	Nitrile



Inch Parts Listing - Shaft Seals

All PEER Part #'s prefixed with "POS"

PEER Part #	Shaft	Bore	Width	Lip Mat.	PEER Part #	Shaft	Bore	Width	Lip Mat.
2253137TB-S	2.250	3.125	0.375	Nitrile	2503525VH-S	2.500	3.505	0.250	Nitrile
2253150SA	2.250	3.125	0.500	Nitrile	2503543SA	2.500	3.543	0.438	Nitrile
2253143SA	2.250	3.189	0.437	Nitrile	2503543TA	2.500	3.543	0.500	Nitrile
2253143TA	2.250	3.189	0.437	Nitrile	2503637TA	2.500	3.623	0.375	Nitrile
2253237TB-S	2.250	3.251	0.375	Nitrile	2503743SA	2.500	3.751	0.438	Nitrile
22533537TA	2.250	3.350	0.375	Nitrile	2503750TA-S	2.500	3.751	0.500	Nitrile
2253337TA	2.250	3.371	0.375	Nitrile	2503846TA	2.500	3.876	0.468	Nitrile
2253337TBN	2.250	3.371	0.375	Nitrile	2504046SA	2.500	4.003	0.468	Nitrile
2253337VB	2.250	3.371	0.375	Nitrile	2553137VB	2.558	3.125	0.375	Nitrile
2253343TA	2.250	3.371	0.438	Nitrile	2563637TA	2.562	3.623	0.375	Nitrile
2253543TA	2.250	3.500	0.438	Nitrile	2563737TA	2.562	3.750	0.375	Nitrile
2253646TA	2.250	3.623	0.468	Nitrile	2623243SA	2.625	3.251	0.438	Nitrile
2253743SA-S	2.250	3.751	0.438	Nitrile	2623337TA-S	2.625	3.350	0.375	Nitrile
2253750TA	2.250	3.751	0.500	Nitrile	26233737TA	2.625	3.371	0.375	Nitrile
2254043SA	2.250	4.003	0.438	Nitrile	26233746TA	2.625	3.374	0.468	Nitrile
2313137TB	2.312	3.125	0.375	Nitrile	26235043TA	2.625	3.500	0.375	Nitrile
2313237TA	2.312	3.251	0.375	Nitrile	2623637TA	2.625	3.623	0.375	Nitrile
2313337TA	2.312	3.350	0.375	Nitrile	2623637TB	2.625	3.623	0.375	Nitrile
2313346SA	2.312	3.371	0.468	Nitrile	2623643TA-S	2.625	3.623	0.438	Nitrile
2313537TA	2.312	3.500	0.375	Nitrile	2623646TB-P-S	2.625	3.623	0.468	Polyacrylate
2373037TB	2.375	3.000	0.375	Nitrile	2623737TA	2.625	3.751	0.375	Nitrile
2373137TB	2.375	3.125	0.375	Nitrile	2623841UAY	2.625	3.813	0.415	Nitrile
23733537TA	2.375	3.350	0.375	Nitrile	2623846TA	2.625	3.876	0.468	Nitrile
2373343TA	2.375	3.371	0.438	Nitrile	2624037TA	2.625	4.003	0.375	Nitrile
2373443TA	2.375	3.481	0.438	Nitrile	2753537SB-S	2.750	3.500	0.375	Nitrile
2373543TA-S	2.375	3.500	0.438	Nitrile	2753537TA	2.750	3.500	0.375	Nitrile
2373635SB	2.375	3.623	0.359	Nitrile	27535343SA	2.750	3.538	0.437	Nitrile
2373637TA-S	2.375	3.623	0.375	Nitrile	27535443TA-P-S	2.750	3.543	0.438	Polyacrylate
2373643SA-S	2.375	3.623	0.438	Nitrile	2753637TA	2.750	3.623	0.375	Nitrile
2373837TA	2.375	3.876	0.375	Nitrile	2753725UB	2.750	3.751	0.250	Nitrile
2433137TB	2.437	3.125	0.375	Nitrile	2753725VH	2.750	3.751	0.250	Nitrile
2433243TA	2.437	3.251	0.437	Nitrile	2753725VHY	2.750	3.751	0.250	Nitrile
2433337TA	2.437	3.350	0.375	Nitrile	2753743TA-S	2.750	3.751	0.438	Nitrile
24333737TA	2.437	3.371	0.375	Nitrile	2753743SA	2.750	3.751	0.438	Nitrile
2433537TA	2.437	3.543	0.375	Nitrile	2753837TA-S	2.750	3.876	0.375	Nitrile
2443529UA	2.445	3.543	0.290	Nitrile	2753843TA-P-S	2.750	3.876	0.433	Polyacrylate
2473235TBY	2.470	3.251	0.350	Nitrile	2753846SB	2.750	3.876	0.468	Nitrile
2473529UA	2.474	3.543	0.290	Nitrile	2754043SA-S	2.750	4.003	0.438	Nitrile
2503137TB	2.500	3.189	0.375	Nitrile	2754043TA-CSP	2.750	4.003	0.438	Polyacrylate
2503225VH	2.500	3.251	0.250	Nitrile	2843950TB-S	2.844	3.939	0.500	Nitrile
2503237TB	2.500	3.251	0.375	Nitrile	2873637TA-S	2.875	3.623	0.375	Nitrile
2503237TB-V	2.500	3.251	0.375	Viton	2873737TA	2.875	3.751	0.375	Nitrile
2503243TA-S	2.500	3.251	0.438	Nitrile	2873837TA	2.875	3.876	0.375	Nitrile
2503346TA	2.500	3.350	0.468	Nitrile	2874037TA-S	2.875	4.003	0.375	Nitrile
25033737TA	2.500	3.371	0.375	Nitrile	2874137TA	2.875	4.125	0.375	Nitrile
2503437TB	2.500	3.428	0.375	Nitrile	2874446SA	2.875	4.499	0.468	Nitrile
25035037TA-S	2.500	3.500	0.375	Nitrile	2874543SA	2.875	4.501	0.438	Nitrile
25035037TA-CSV	2.500	3.500	0.375	Viton	2874543TA	2.875	4.501	0.438	Nitrile

Inch Parts Listing – Shaft Seals



All PEER Part #'s prefixed with "POS"

PEER Part #	Shaft	Bore	Width	Lip Mat.	PEER Part #	Shaft	Bore	Width	Lip Mat.
2874643TA	2.875	4.625	0.437	Nitrile	3504543TA	3.500	4.501	0.438	Nitrile
2933737TA	2.937	3.751	0.375	Nitrile	3504546TA	3.500	4.501	0.468	Nitrile
2934037TA	2.937	4.003	0.375	Nitrile	3504946TA	3.500	4.999	0.468	Nitrile
2934543SA	2.938	4.501	0.438	Nitrile	3505143TA	3.500	5.126	0.438	Nitrile
3003743TA-S	3.000	3.751	0.438	Nitrile	3505246TA	3.500	5.251	0.468	Nitrile
3003843TA	3.000	3.876	0.437	Nitrile	3505550TA	3.500	5.500	0.500	Nitrile
3004025VH	3.000	4.003	0.250	Nitrile	3624337TA	3.625	4.376	0.375	Nitrile
3004037TA	3.000	4.003	0.375	Nitrile	3624750TA	3.625	4.751	0.500	Nitrile
3004037TA-CSV	3.000	4.003	0.375	Viton	3624850TA-S	3.625	4.875	0.500	Nitrile
3004043TA-P	3.000	4.003	0.438	Polyacrylate	3624950TA	3.625	4.999	0.500	Nitrile
3004046SA	3.000	4.003	0.468	Nitrile	3625243TA	3.625	5.251	0.437	Nitrile
3004143TA	3.000	4.125	0.437	Nitrile	3754546TA-P-S	3.750	4.501	0.469	Polyacrylate
3004143SA-S	3.000	4.125	0.438	Nitrile	3754750TA	3.750	4.751	0.500	Nitrile
3004243TA	3.000	4.249	0.437	Nitrile	3754943TA	3.750	4.999	0.438	Nitrile
3004243TA-P-S	3.000	4.249	0.438	Polyacrylate	3755246TA	3.750	5.251	0.468	Nitrile
3004350TA-S	3.000	4.331	0.500	Nitrile	3755350TA	3.750	5.376	0.500	Nitrile
3004543SA	3.000	4.500	0.438	Nitrile	3756050SA	3.750	6.001	0.500	Nitrile
3004543TA	3.000	4.500	0.438	Nitrile	3874737TA	3.875	4.751	0.375	Nitrile
3004946SA	3.000	4.999	0.468	Nitrile	3874850TA-S	3.875	4.875	0.500	Nitrile
3124037TA	3.125	4.003	0.375	Nitrile	3874950TA	3.875	4.999	0.500	Nitrile
3124137TA	3.125	4.125	0.375	Nitrile	3875243SA-S	3.875	5.251	0.438	Nitrile
3124243TA	3.125	4.249	0.438	Nitrile	3875243TA-S	3.875	5.251	0.438	Nitrile
3124350TA	3.125	4.375	0.500	Nitrile	3875350TA	3.875	5.376	0.500	Nitrile
3124643TA	3.125	4.626	0.437	Nitrile	3875550TA	3.875	5.501	0.500	Nitrile
3124750TA	3.125	4.751	0.500	Nitrile	4004862TA	4.000	4.876	0.625	Nitrile
3124946TA	3.125	4.999	0.468	Nitrile	4004943TA	4.000	4.999	0.438	Nitrile
3124946TB	3.125	4.999	0.468	Nitrile	4004950TA-S	4.000	4.999	0.500	Nitrile
3125246TA	3.125	5.251	0.468	Nitrile	4005350TA	4.000	5.376	0.500	Nitrile
3184243SA	3.188	4.249	0.438	Nitrile	40055556TA	4.000	5.501	0.562	Nitrile
3184543SA	3.188	4.501	0.438	Nitrile	4005637TA	4.000	5.626	0.375	Nitrile
3254037TA	3.250	4.004	0.375	Nitrile	4005756TA	4.000	5.751	0.562	Nitrile
3254237TB	3.250	4.249	0.375	Nitrile	4006250TA	4.000	6.250	0.500	Nitrile
3254350TA	3.250	4.376	0.500	Nitrile	4124943SA	4.125	4.999	0.438	Nitrile
3254525VH	3.250	4.501	0.250	Nitrile	4125150TA	4.125	5.126	0.500	Nitrile
3254537TA	3.250	4.500	0.375	Nitrile	4125550TA	4.125	5.501	0.500	Nitrile
3254543TA	3.250	4.501	0.438	Nitrile	4125756TA	4.125	5.751	0.562	Nitrile
3254650TA	3.250	4.626	0.500	Nitrile	4255250TA-S	4.250	5.250	0.500	Nitrile
3254746TA	3.250	4.723	0.468	Nitrile	4255237TB	4.250	5.251	0.375	Nitrile
3254748SA	3.250	4.751	0.484	Nitrile	4255350TA	4.250	5.376	0.500	Nitrile
3254946TA	3.250	4.999	0.468	Nitrile	4255650TA	4.250	5.626	0.500	Nitrile
3374137TA	3.375	4.125	0.375	Nitrile	4255756TA	4.250	5.751	0.562	Nitrile
3374250TA	3.375	4.249	0.500	Nitrile	4255950TA	4.250	5.999	0.500	Nitrile
3374337TA	3.375	4.376	0.375	Nitrile	4256150TA	4.250	6.126	0.500	Nitrile
3374643SA	3.375	4.626	0.438	Nitrile	4256256TA	4.250	6.250	0.562	Nitrile
3374643TA	3.375	4.626	0.438	Nitrile	4375756TA	4.375	5.751	0.562	Nitrile
3374946TA	3.375	4.999	0.468	Nitrile	4376050SA	4.375	6.001	0.500	Nitrile
3504025VB-S	3.500	4.003	0.250	Nitrile	4505243TC	4.500	5.251	0.437	Nitrile
3504350TA-S	3.500	4.376	0.500	Nitrile	4505343TA	4.500	5.376	0.437	Nitrile



Inch Parts Listing - Shaft Seals

All PEER Part #'s prefixed with "POS"

PEER Part #	Shaft	Bore	Width	Lip Mat.	PEER Part #	Shaft	Bore	Width	Lip Mat.
4506750SA	4.500	6.750	0.500	Nitrile	7378875SA	7.375	8.875	0.750	Nitrile
4507550KA	4.500	7.500	0.500	Nitrile	7379075TA-S	7.375	9.000	0.750	Nitrile
4507550TA	4.500	7.500	0.500	Nitrile	7508562TA	7.500	8.500	0.625	Nitrile
4625756TA	4.625	5.751	0.562	Nitrile	7509075TA	7.500	9.000	0.750	Nitrile
4685750TA-S	4.687	5.751	0.500	Nitrile	7629162TA	7.625	9.125	0.625	Nitrile
4756050TA	4.750	6.001	0.500	Nitrile	7759262SA	7.750	9.250	0.625	Nitrile
4756256TA	4.750	6.250	0.562	Nitrile	8009262TA	8.000	9.250	0.625	Nitrile
4876250TA	4.875	6.250	0.500	Nitrile	8009562TA	8.000	9.500	0.625	Nitrile
4935950TA-S	4.937	5.999	0.500	Nitrile	80010062TA	8.000	10.000	0.625	Nitrile
4936250TA	4.937	6.250	0.500	Nitrile	81210175SA	8.125	10.125	0.750	Nitrile
4936350TA	4.937	6.374	0.500	Nitrile	85010062TA	8.500	10.000	0.625	Nitrile
5006050TA	5.000	6.001	0.500	Nitrile	85010562TA	8.500	10.500	0.625	Nitrile
5006250TA	5.000	6.250	0.500	Nitrile	85010675TA	8.500	10.625	0.750	Nitrile
5006350TA	5.000	6.375	0.500	Nitrile	86210675TA	8.625	10.625	0.750	Nitrile
5006750TA	5.000	6.749	0.500	Nitrile	90011075TA	9.000	11.000	0.750	Nitrile
5007550TA	5.000	7.500	0.500	Nitrile	92511275TA	9.250	11.250	0.750	Nitrile
5126250TA	5.125	6.250	0.500	Nitrile	95011562TA	9.500	11.500	0.625	Nitrile
5256250TA	5.250	6.250	0.500	Nitrile	10012062TA	10.000	12.000	0.625	Nitrile
5256556TA	5.250	6.500	0.562	Nitrile	10212275TA	10.250	12.250	0.750	Nitrile
5256750TA	5.250	6.750	0.500	Nitrile	10512510TA	10.500	12.500	1.000	Nitrile
5316550TA-S	5.312	6.500	0.500	Nitrile	11012562TA	11.000	12.500	0.625	Nitrile
5506250TB	5.500	6.250	0.500	Nitrile	11013075TA	11.000	13.000	0.750	Nitrile
5506556TA	5.500	6.500	0.562	Nitrile	11513075TA	11.500	13.000	0.750	Nitrile
5506757TA	5.500	6.750	0.575	Nitrile	11513575TA	11.500	13.500	0.750	Nitrile
5507062TA-S	5.500	7.000	0.625	Nitrile	12014075TA	12.000	14.000	0.750	Nitrile
5627150TA	5.625	7.125	0.500	Nitrile					
5756757TA	5.750	6.750	0.575	Nitrile					
5877150TA	5.875	7.125	0.500	Nitrile					
5877556SA	5.875	7.500	0.562	Nitrile					
6007550TA	6.000	7.500	0.500	Nitrile					
6127162SA	6.125	7.125	0.625	Nitrile					
6257556SA	6.250	7.500	0.562	Nitrile					
6257750TA	6.250	7.750	0.500	Nitrile					
6257875TA	6.250	7.875	0.750	Nitrile					
6377850TA-S	6.375	7.875	0.500	Nitrile					
6377856TA	6.375	7.875	0.563	Nitrile					
6507556TA	6.500	7.500	0.562	Nitrile					
6508062TA	6.500	8.000	0.625	Nitrile					
6628162TA	6.625	8.125	0.625	Nitrile					
6758062TA	6.750	8.000	0.625	Nitrile					
6758256TA	6.750	8.250	0.562	Nitrile					
6878362SA	6.875	8.375	0.625	Nitrile					
7008062TA	7.000	8.000	0.625	Nitrile					
7008262TA	7.000	8.250	0.625	Nitrile					
7008562TA	7.000	8.500	0.625	Nitrile					
7128656TA	7.125	8.625	0.562	Nitrile					
7258262TA	7.250	8.250	0.625	Nitrile					
7258775TA	7.250	8.750	0.750	Nitrile					

Metric Parts Listing – Shaft Seals



All PEER Part #'s prefixed with "POS"

PEER Part #	Shaft	Bore	Width	Lip Mat.	PEER Part #	Shaft	Bore	Width	Lip Mat.
5156TC	5.00	15.00	6.00	Nitrile	20307TC	20.00	30.00	7.00	Nitrile
8123VC	8.00	12.00	3.00	Nitrile	20357TC	20.00	35.00	7.00	Nitrile
8167TC	8.00	16.00	7.00	Nitrile	20367TC	20.00	36.00	7.00	Nitrile
8185TC	8.00	18.00	5.00	Nitrile	20407TC	20.00	40.00	7.00	Nitrile
10197TC	10.00	19.00	7.00	Nitrile	20427SC	20.00	42.00	7.00	Nitrile
10227TC	10.00	22.00	7.00	Nitrile	20427TC	20.00	42.00	7.00	Nitrile
10227TF-CSV	10.00	22.00	7.00	Viton	20477SC	20.00	47.00	7.00	Nitrile
10247TC	10.00	24.00	7.00	Nitrile	22327TC	22.00	32.00	7.00	Nitrile
10257TC	10.00	25.00	7.00	Nitrile	22357TC	22.00	35.00	7.00	Nitrile
10267TC	10.00	26.00	7.00	Nitrile	22358TB-S	22.00	35.00	8.00	Nitrile
11174TC	11.00	17.00	4.00	Nitrile	22388TC	22.00	38.00	8.00	Nitrile
12195TC	12.00	19.00	5.00	Nitrile	22408SC	22.00	40.00	8.00	Nitrile
12205TC	12.00	20.00	5.00	Nitrile	22427TC	22.00	42.00	7.00	Nitrile
12227TC	12.00	22.00	7.00	Nitrile	22477TC	22.00	47.00	7.00	Nitrile
12247TC	12.00	24.00	7.00	Nitrile	22478SB-S	22.00	47.00	8.00	Nitrile
12257TC	12.00	25.00	7.00	Nitrile	24358TC	24.00	35.00	8.00	Nitrile
12267TC	12.00	26.00	7.00	Nitrile	24377SC	24.00	37.00	7.00	Nitrile
12287TC	12.00	28.00	7.00	Nitrile	24388TC	24.00	38.00	8.00	Nitrile
14224TC	14.00	22.00	4.00	Nitrile	24407SC	24.00	40.00	7.00	Nitrile
14247TC	14.00	24.00	7.00	Nitrile	24527TC	24.00	52.00	7.00	Nitrile
14287TC	14.00	28.00	7.00	Nitrile	25357SC	25.00	35.00	7.00	Nitrile
15247TC	15.00	24.00	7.00	Nitrile	25357TC	25.00	35.00	7.00	Nitrile
15255TC	15.00	25.00	5.00	Nitrile	25357TB2-S	25.00	35.00	7.80	Nitrile
15267TC	15.00	26.00	7.00	Nitrile	25357TB2-V-S	25.00	35.00	7.80	Viton
15287TC	15.00	28.00	7.00	Nitrile	25357TM2-S	25.00	35.00	7.80	Nitrile
15307TC	15.00	30.00	7.00	Nitrile	25367TC	25.00	36.00	7.00	Nitrile
15327TC	15.00	32.00	7.00	Nitrile	25366SC-CS	25.00	36.50	6.00	Nitrile
15357TC	15.00	35.00	7.00	Nitrile	25377TC	25.00	37.00	7.00	Nitrile
16247TC	16.00	24.00	7.00	Nitrile	25387TC	25.00	38.00	7.00	Nitrile
16267TC	16.00	26.00	7.00	Nitrile	25407SB	25.00	40.00	7.00	Nitrile
16287TC	16.00	28.00	7.00	Nitrile	25408TB2-V-S	25.00	40.00	8.00	Viton
16307TC	16.00	30.00	7.00	Nitrile	25408TC	25.00	40.00	8.00	Nitrile
16327TC	16.00	32.00	7.00	Nitrile	25427TC	25.00	42.00	7.00	Nitrile
16357TC	16.00	35.00	7.00	Nitrile	25447TC	25.00	44.00	7.00	Nitrile
17244TB-S	17.00	24.00	4.00	Nitrile	25458TC	25.00	45.00	8.00	Nitrile
17287TC	17.00	28.00	7.00	Nitrile	25467TC	25.00	46.00	7.00	Nitrile
17295TC	17.00	29.00	5.00	Nitrile	2547TBY-S	25.00	47.00		Nitrile
17307SC	17.00	30.00	7.00	Nitrile	25477TC	25.00	47.00	7.00	Nitrile
17327TC	17.00	32.00	7.00	Nitrile	25478TB2-S	25.00	47.00	8.00	Nitrile
17358TC	17.00	35.00	8.00	Nitrile	254710TC	25.00	47.00	10.00	Nitrile
17407SC	17.00	40.00	7.00	Nitrile	255210SC	25.00	52.00	10.00	Nitrile
17478TC	17.00	47.00	8.00	Nitrile	25627TC	25.00	62.00	7.00	Nitrile
18287TC	18.00	28.00	7.00	Nitrile	258010TB2-S	25.00	80.00	10.00	Nitrile
18307TC	18.00	30.00	7.00	Nitrile	26377TC	26.00	37.00	7.00	Nitrile
18327TC	18.00	32.00	7.00	Nitrile	26388TC	26.00	38.00	8.00	Nitrile
18357TC	18.00	35.00	7.00	Nitrile	26388TC-CS	26.00	38.00	8.00	Nitrile
19328TC	19.00	32.00	8.00	Nitrile	26407TC	26.00	40.00	7.00	Nitrile
20275TB-S	20.00	27.00	5.00	Nitrile	26427TC	26.00	42.00	7.00	Nitrile



Metric Parts Listing - Shaft Seals

All PEER Part #'s prefixed with "POS"

PEER Part #	Shaft	Bore	Width	Lip Mat.	PEER Part #	Shaft	Bore	Width	Lip Mat.
26477SC	26.00	47.00	7.00	Nitrile	358010TC	35.00	80.00	10.00	Nitrile
27377TC	27.00	37.00	7.00	Nitrile	36477SC	36.00	47.00	7.00	Nitrile
27438TC	27.00	43.00	8.00	Nitrile	36527SC	36.00	52.00	7.00	Nitrile
28387SC	28.00	38.00	7.00	Nitrile	36547TC	36.00	54.00	7.00	Nitrile
28408TC	28.00	40.00	8.00	Nitrile	36627TC	36.00	62.00	7.00	Nitrile
28428TC	28.00	42.00	8.00	Nitrile	38507SC	38.00	50.00	7.00	Nitrile
28477TC	28.00	47.00	7.00	Nitrile	38527TC	38.00	52.00	7.00	Nitrile
29477TC	29.00	47.00	7.00	Nitrile	38558TC	38.00	55.00	8.00	Nitrile
30407SB	30.00	40.00	7.00	Nitrile	38558TC-CS	38.00	55.00	8.00	Nitrile
30407TC	30.00	40.00	7.00	Nitrile	386010SC	38.00	60.00	10.00	Nitrile
30427SC	30.00	42.00	7.00	Nitrile	386510TC	38.00	65.00	10.00	Nitrile
30457TC	30.00	45.00	7.00	Nitrile	387210SC	38.00	72.00	10.00	Nitrile
30458SB-S	30.00	45.00	8.00	Nitrile	387411TC	38.00	74.00	11.00	Nitrile
30458SC	30.00	45.00	8.00	Nitrile	40508SC	40.00	50.00	8.00	Nitrile
30467TC	30.00	46.00	7.00	Nitrile	40527TC	40.00	52.00	7.00	Nitrile
30477SB	30.00	47.00	7.00	Nitrile	40558TC	40.00	55.00	8.00	Nitrile
30477TC	30.00	47.00	7.00	Nitrile	40567TC	40.00	56.00	7.00	Nitrile
30488SC	30.00	48.00	8.00	Nitrile	40589TC	40.00	58.00	9.00	Nitrile
30507SC	30.00	50.00	7.00	Nitrile	406010SC	40.00	60.00	10.00	Nitrile
30516SC	30.00	51.00	6.00	Nitrile	406510SC	40.00	65.00	10.00	Nitrile
30528TC	30.00	52.00	8.00	Nitrile	40688TC	40.00	68.00	8.00	Nitrile
305510SC	30.00	55.00	10.00	Nitrile	40707TB2-S	40.00	70.00	7.00	Nitrile
30628TC	30.00	62.00	8.00	Nitrile	407010TC	40.00	70.00	10.00	Nitrile
307210SC	30.00	72.00	10.00	Nitrile	407210TC	40.00	72.00	10.00	Nitrile
32437TC	32.00	43.00	7.00	Nitrile	407512TC	40.00	75.00	12.00	Nitrile
32457TC	32.00	45.00	7.00	Nitrile	408010SC	40.00	80.00	10.00	Nitrile
32477SC	32.00	47.00	7.00	Nitrile	42557TC	42.00	55.00	7.00	Nitrile
32488TC	32.00	48.00	8.00	Nitrile	42567TC	42.00	56.00	7.00	Nitrile
32528TC	32.00	52.00	8.00	Nitrile	42609TC	42.00	60.00	9.00	Nitrile
32528TC-CS	32.00	52.00	8.00	Nitrile	42609TC-CS	42.00	60.00	9.00	Nitrile
32728TC	32.00	72.00	8.00	Nitrile	42628TC	42.00	62.00	8.00	Nitrile
33457SC	33.00	45.00	7.00	Nitrile	426810TC	42.00	68.00	10.00	Nitrile
33506TC	33.00	50.00	6.00	Nitrile	427210TC	42.00	72.00	10.00	Nitrile
34468TC	34.00	46.00	8.00	Nitrile	436010SC	43.00	60.00	10.00	Nitrile
34487TC	34.00	48.00	7.00	Nitrile	43628TC	43.00	62.00	8.00	Nitrile
34528TC	34.00	52.00	8.00	Nitrile	44607TC	44.00	60.00	7.00	Nitrile
35457SC	35.00	45.00	7.00	Nitrile	44728SB	44.00	72.00	8.00	Nitrile
35477TC	35.00	47.00	7.00	Nitrile	45587SC	45.00	58.00	7.00	Nitrile
35478TC2	35.00	47.00	8.00	Nitrile	45607SC	45.00	60.00	7.00	Nitrile
35488TC	35.00	48.00	8.00	Nitrile	45628TC	45.00	62.00	8.00	Nitrile
35488TC-CS	35.00	48.00	8.00	Nitrile	45658SC	45.00	65.00	8.00	Nitrile
35507SC	35.00	50.00	7.00	Nitrile	45687TC	45.00	68.00	7.00	Nitrile
35527SC	35.00	52.00	7.00	Nitrile	457210TC	45.00	72.00	10.00	Nitrile
35547SB	35.00	54.00	7.00	Nitrile	45757TC	45.00	75.00	7.00	Nitrile
35558TC	35.00	55.00	8.00	Nitrile	458010TC	45.00	80.00	10.00	Nitrile
35628TB2-S	35.00	62.00	8.00	Nitrile	458510SC	45.00	85.00	10.00	Nitrile
356210TC	35.00	62.00	10.00	Nitrile	48628TC	48.00	62.00	8.00	Nitrile
357210TC	35.00	72.00	10.00	Nitrile	486510TC	48.00	65.00	10.00	Nitrile

Metric Parts Listing – Shaft Seals



All PEER Part #'s prefixed with "POS"

PEER Part #	Shaft	Bore	Width	Lip Mat.	PEER Part #	Shaft	Bore	Width	Lip Mat.
487410TC	48.00	74.00	10.00	Nitrile	709012TC	70.00	90.00	12.00	Nitrile
50627TC	50.00	60.00	7.00	Nitrile	709212TC	70.00	92.00	12.00	Nitrile
50658TC	50.00	65.00	8.00	Nitrile	709513SC	70.00	95.00	13.00	Nitrile
50688SC	50.00	68.00	8.00	Nitrile	7010010TC	70.00	100.00	10.00	Nitrile
50698TB2-S	50.00	69.85	8.00	Nitrile	72969TC	72.00	96.00	9.00	Nitrile
507010TC	50.00	70.00	10.00	Nitrile	759510TC	75.00	95.00	10.00	Nitrile
50728SC	50.00	72.00	8.00	Nitrile	7510010TC	75.00	100.00	10.00	Nitrile
507210TB	50.00	72.00	10.00	Nitrile	7510513TC	75.00	105.00	13.00	Nitrile
507210TC	50.00	72.00	10.00	Nitrile	7511010TC	75.00	110.00	10.00	Nitrile
50808SC	50.00	80.00	8.00	Nitrile	751208UA	75.00	120.00	8.13	Nitrile
50908TC	50.00	90.00	8.00	Nitrile	7512013TC	75.00	120.00	13.00	Nitrile
51657TB-S	51.00	65.00	7.00	Nitrile	7810010SC	78.00	100.00	10.00	Nitrile
52688SC	52.00	68.00	8.00	Nitrile	8010010SC	80.00	100.00	10.00	Nitrile
52709TC	52.00	70.00	8.00	Nitrile	8010510TC	80.00	105.00	10.00	Nitrile
52728TC	52.00	72.00	8.00	Nitrile	8011010TC	80.00	110.00	10.00	Nitrile
547210TC	54.00	72.00	10.00	Nitrile	8511010TB-CSV-S	85.00	110.00	10.00	Viton
55688TC	55.00	68.00	8.00	Nitrile	8511013TC	85.00	110.00	13.00	Nitrile
55708SB-S	55.00	70.00	8.00	Nitrile	8511513SC	85.00	115.00	13.00	Nitrile
55708SB-CSV-S	55.00	70.00	8.00	Viton	8512012TC	85.00	120.00	12.00	Nitrile
55708TC	55.00	70.00	8.00	Nitrile	9011012SC	90.00	110.00	12.00	Nitrile
557812TC	55.00	78.00	12.00	Nitrile	9011512TB-S	90.00	115.00	12.00	Nitrile
558010SC	55.00	80.00	10.00	Nitrile	9512012TB-V-S	95.00	120.00	12.00	Viton
558510SC	55.00	85.00	10.00	Nitrile	9512012TC	95.00	120.00	12.00	Nitrile
56728TC	56.00	72.00	8.00	Nitrile	9513012SC	95.00	130.00	12.00	Nitrile
56758TC	56.00	75.00	8.00	Nitrile	10012010SC	100.00	120.00	10.00	Nitrile
58728SC	58.00	72.00	8.00	Nitrile	10012512SC	100.00	125.00	12.00	Nitrile
60758SC	60.00	75.00	8.00	Nitrile	10013012SC	100.00	130.00	12.00	Nitrile
60789TC	60.00	78.00	9.00	Nitrile	10513012SC	105.00	130.00	12.00	Nitrile
608010TC	60.00	80.00	10.00	Nitrile	10514012SC	105.00	140.00	12.00	Nitrile
608212TC	60.00	82.00	12.00	Nitrile	11014012TC	110.00	140.00	12.00	Nitrile
60858SC	60.00	85.00	8.00	Nitrile	11514012SC	115.00	140.00	12.00	Nitrile
609010SC	60.00	90.00	10.00	Nitrile	11514514TC	115.00	145.00	14.00	Nitrile
609010TC	60.00	90.00	10.00	Nitrile	12014013SC	120.00	140.00	13.00	Nitrile
609510TC	60.00	95.00	10.00	Nitrile	12015012SC	120.00	150.00	12.00	Nitrile
628010SC	62.00	80.00	10.00	Nitrile	12015012TF-CSV	120.00	150.00	12.00	Viton
628510SC	62.00	85.00	10.00	Nitrile	12515012TC	125.00	150.00	12.00	Nitrile
629010SC	62.00	90.00	10.00	Nitrile	12516012SC	125.00	160.00	12.00	Nitrile
63809TC	63.00	80.00	9.00	Nitrile	13016012SC	130.00	160.00	12.00	Nitrile
63809TC-CS	63.00	80.00	9.00	Nitrile	14017012TC	140.00	170.00	12.00	Nitrile
639010TC	63.00	90.00	10.00	Nitrile	14017013SC	140.00	170.00	13.00	Nitrile
65808TC	65.00	80.00	8.00	Nitrile	15018015TC	150.00	180.00	15.00	Nitrile
658510SC	65.00	85.00	10.00	Nitrile	16018510SC	160.00	185.00	10.00	Nitrile
658810TC	65.00	88.00	10.00	Nitrile	16019015SC	160.00	190.00	15.00	Nitrile
659010SC	65.00	90.00	10.00	Nitrile	18021015SC	180.00	210.00	15.00	Nitrile
6510010SC	65.00	100.00	10.00	Nitrile	19023016TC	190.00	230.00	16.00	Nitrile
67849TC9-CS	67.00	84.00	9.00	Nitrile	22025015SC	220.00	250.00	15.00	Nitrile
689010SC	68.00	90.00	10.00	Nitrile	24027015SC	240.00	270.00	15.00	Nitrile
70858SC	70.00	85.00	8.00	Nitrile					



Inch Interchange - Shaft Seals

BOLD NUMBERS ARE EXACT EQUIVALENTS. ALL OTHERS ARE CLOSEST EQUIVALENTS. All PEER Part #'s prefixed with "POS"

PEER	Transcom	CR/SKF	National
0186225VC			
0257525SC-SS	02072SC	2514	350435
0319937TB	0310937TB-H	3171	470195
0375609VB	03050VB	3621	340827
0376815VB-S	03061VM	3645	311189
0377525TB	03072SB	3680	330385
0378725SC	03082SC	3725	473096
0378725TB	03082TB	3725	473096
0379925TB	03092SM	3751	471103
0438318VB	04081VM	4231	
0438725SM	04082SM	4251	482810
0439937SB	04093SB-H	4355	470199
0507512VB-S	05071VB	4912	340847
0508712VM	05081VM	4925	330699
0508725VB	05082VB	4931	330699
0509925TB	05092TB	4985	471442
0509925TB-S	05092TB	4985	471442
0501025TC	050102TC	4985	471490
0501037SZ-V			
0501125TB	05112TB	5062	471526
0501125TC	05112TB	5062	471526
0501131TBW-SS		539245	
0501225TB	05122TC	5133	471472
0501325TB	05132TB-H	5150	471549
0531131TB	053113TB-H	5334	471530
0561025TB-S	056092SB	5606	472705
0561225TB	056122TB-H	5707	471535
0561325TB	056132TB-H	5756	471551
0569925SB	056092SB	5541	481315
0561125TB	056112TB	5662	471281
0591131TB	059113TB-H	5926	471532
0591231TB	059123TB-H	5950	473405
0591331TB-S	059133TB-H	5966	471558
0591125VB	059112VB	5946	471532
0628109VM	060809VM	6105	340387
0628112VM-SC	06081VM	6105	340387
0621125TB	06112TB	6204	471466
0621125TB-V	06112VTB-H	6215	471466V
0621131SZ-SSV	06112VSB	6213	481466V
0621131TF	061131SC	6204	470791
0621225TB	06122TB	6316	471264
0621237SA-S			450018
0621325TB	06132TB	6373	471255
0621325TB-V	06132VTB-H	6383	471255V
0621325VB-S	06132VB	6370	481255
0621331TB-SS	06132TB	6373	471324
0621425TB	06142TB-H	6386	471564

Inch Interchange - Shaft Seals



BOLD NUMBERS ARE EXACT EQUIVALENTS. ALL OTHERS ARE CLOSEST EQUIVALENTS. All PEER Part #'s prefixed with "POS"

PEER	Transcom	CR/SKF	National
0621525TB-S	061562TB-H		
0629925TB-S	06092TB	6141	7188S
0651125SB	065112SB-H	6521	481528
0651225SB-S	065122SB-H	6541	481537
0651331SB	065133SB-H	6556	481073
0651525SB	065152SB-H	6580	481397
0660918SB		6595	
0661131TC	066122VB		
0661131TF	066122VB		
06871625TB	068162TB-H	6990	471642
06811225SB	068112SB	6741	481529
0681118SB	06111SB	6763	474261
0681231SB	068122SB-H	6767	471538
0681425SB	068142SB	6935	471579
0711237TB	07123TB-H		470506
0750912VM	07091VM	7410	240735
0751115VM	07111VM	7415	254270
0751118SB	071118SM	7414	7750
0751118SB-S	071118SM	7414	7750
0751118SB-CSV-S	071118VSB-H	7417	7750
0751225SB	07122SB	7440	480954
0751225TB	07122TB	7443	470954
0751225TB-CSV	07122VTB-H	7455	470954V
0751225TC	07122TC-G	7443	470954
0751225TF	07122TC-G	7443	470954
07513125SB	07132TB	7474	480821
0751325SB-S	075132TB	7512	470027
0751325TB-S	075132TB	7513	471554
0751325TB-CSV	07132VTB-H	7517	471554V
0751325TC-P	07132PTC	7533	481554N
0751325TC-SS	07132PTC	7513	471554
0751425SB	07142SB	7572	471567
0751425TB-S	07142TB-H	7573	471567
0751625TB	07162TB	7628	471643
0751725TB	07172TB-H	7638	471684
07517825TB	071782SL		473196
0751825TB	07182TB-H	7690	470390
0752031TB	072043TB-H	7693	472649
0781225TB	078122TB-H		470601
0781331SB	078133SB	7829	481443
0781431SB	07143SB	7849	481568
0781625SB-S	078162SB-H	7872	481644
0781631TB	0781631TB-H	7872	481644
0781825TB	078182TB-H	7889	474273
07871118SB-S	078111SB	7740	
0811225TB	081122TB-H	8017	471539
0811325SB	0811312SB-H	8027	480889
0811331TB	081133TB-H	8060	471231



Inch Interchange - Shaft Seals

BOLD NUMBERS ARE EXACT EQUIVALENTS. ALL OTHERS ARE CLOSEST EQUIVALENTS. All PEER Part #'s prefixed with "POS"

PEER	Transcom	CR/SKF	National
0811537SA	081153SA-H		450588
0811625TB-CSV	081162VTB-H	8178	471645V
0812437TB	08243TB-H		472950
0841331TB	084133TB-H		472452
0841831TB	084183TB-H	8485	473415
0862025TB	22X52X10TC		22X52X8
0871112VB	08111VB	8620	240733
0871218SB	08121SB	8624	42280S
0871218TB	08121TB	8624	254287
0871325TB	08132TB	8648	471267
0871325TB-V	08132VTB-H	8646	471267V
0871331TA	08133TA	8660	410567
0871425TB-S	08142TB-H	8702	471570
0871425TB-CSV-S	08142VTB-H	8707	471570V
0871431SB	08153SB	8703	480680
0871625TB	08162TB	8782	471646
0871725TB	08172TB	8821	470590
0871837TB	08183TB-H	8842	471137
0871825TB	08182TB-H	8860	471730
0901439TB	090143TB-H		470207
0931425TB	093142TB	9298	471571
0931425TB-CSV	093142VTB-H		471571V
0931625TB	093162TB	9307	471647
0931725TB	093172TB-H	9347	474252
0931843SA	09184SA-H	9409	450039
0961431SA	09143SA	9613	451583
0961625TB	09162TB-H	9646	471648
0961725TB	09172TB-H	9667	471688
0961843SA	096184SA-H	9681	450040
0981425TB	09142TB	9686	472324
0981425TB-V	09142VTB-H	9686	472324V
0981737TM-SS		9803	483027V
0981737TM-SSV		9803	483027V
09852040TA-S			
10013112VB	101311VL	9818	342517
1001318VM	10131VM	9820	252277
10014325TB-S	101432TB-H	9838	472311
10014325TB-V	101432VTB-H	9847	472311V
1001423SC-CS			
1001425SB	10142SB-H	9876	481224
1001425TB	10142TB-H	9878	471224
1001425TB-V	10142VTB-H	9879	471224V
1001431TB	101503TC	9878	470553
1001525TB-S	101562TB-H	9894	471270
1001518VM			
10015725TB	101572TB	9907	473380
1001625TB-S	10162TB	9935	471649

Inch Interchange - Shaft Seals



BOLD NUMBERS ARE EXACT EQUIVALENTS. ALL OTHERS ARE CLOSEST EQUIVALENTS. All PEER Part #'s prefixed with "POS"

PEER	Transcom	CR/SKF	National
1001625TB-CSV	10162VTB-H	9939	471649V
10016825TB-S	101682TB-H	9960	474250
1001725TB-S	10172TB-H	9998	471689
1001725TB-V	10172VTB-H	9983	471689V
10017846VA5	10174VHY	10035	204005
10017825VH	10174VHY	530484	204005
10017846VB-S	10174VB	10034	203005
10017846VHY-S	10174VHY	10035	204005
1001825TB	100182TB	10049	470593
1001825TB-CS	100182TB	10050	470593
1001825TC	100182TB	10049	470593
1001825TC-CS	100182TB	10050	470593
10018725TB	101872TB-H	10075	471733
1001937TC	10193TB	10114	471744
1001931TB-S	10193TB	10114	471744
1002025SB-CSV-S	10202VSB	10128	481760
1002025TB	10202TB	10124	471760
1002025TB-V	10202VTB-H	10129	471760V
1002025VH-S	10202SB	10153	481760
10020425TB	102042TB	10157	472138
10020431TB-S	1020431TB-H	10157	472138
10020625TB-S	100202TB-H	10158	471619
10023270UB		538266	
1002437TB	10243TB	10178	471516
1061631TM	101683TB-H	10632	470606
1061634TB-T	101683TB-H	10632	470606
1061731TB-S	106173TB-H	10653	471705
1061837TB-S	106183TB-H	10681	473419
10618725TB-S	106182TB-H	10700	471735
1061943SA-S	10194SA-H	10733	450342
1062025TB-S	106202TB-H	10740	471762
1062043SB	106202SB	10740	480158
1062037TB-S	1062063TB-H	10766	473420
10632025SB-S	106202SB	10740	471762
1121418VB-S	11141VB	11060	340815
1121525TB-P	11152PTB-H	11066	472560N
1121625TB	11162TB	11124	471652
1121625TB-CSV	11162VTB-H	11134	471652V
11217525TB-S	11172TB-H	11138	471692
1121725VH	111782VH	11161	
1121746VHY	111784VHY	11164	204020
1121740TC	11174TB		323133
11218225TB-S	11182TB-H	11171	476838
11218531SA-S	11183SA	11197	350974
1121825SB-SSV	111872VSB	11207	470712V
1121825SB-V	111872VSB	11207	470712V
1121825TB-S	111872TB	11223	470712
11219334VB	11195VA3	11269	203003



Inch Interchange - Shaft Seals

BOLD NUMBERS ARE EXACT EQUIVALENTS. ALL OTHERS ARE CLOSEST EQUIVALENTS. All PEER Part #'s prefixed with "POS"

PEER	Transcom	CR/SKF	National
1121925TB-S	111982TB-H	11299	471747
1122025TB	11203TB	11343	471763
1122025TB-V	11202VTB-H	11344	471763V
1122037TB-S	11203TB-H	11343	471763
1122040TA-S	11203TB-H	11343	410160
11220431TB-S	112043TB-H	11353	472644
11220625TB-S	112062TB-H	11366	471785
1122131SB	11213SB	11372	481792
1122250SA-S	11225SA-H	11378	450604
1122425TB-S	11242TB-H	11392	473259
1151625TB	115162TB	11518	474260
1151825SB-S	115182SB-H	11524	481736
1152025TB-S	115202TB-H	11545	471764
1152037TB-S	115203TB-H	11557	473427
1181837TB-S	111823TB-H	11740	473425
1182025TB-S	1182062TB-H	11878	471354
1182043TB-SS	118202TB	11801	470162
1182125TB-S	1182122TB-H	11907	473205
1182225TB-S	118222TB-H	11914	474255
1182425TB-S	112432TB-H	11923	474254
11824425TB-S	118242TB-H	11930	474256
11882025SB	118202SB	11800	481765
1211940VB-S	121974VB	12124	203025
12516218SB-S	125161SB	12329	251511
12516825TB-S	12162TB-H	12336	474278
12516825TB-V	12162VTB-H	12337	473135V
1251631TC	12163TB	12350	322353
1251725TB-S	12172TB	12364	471413
1251725TB-CSV	12172VTB-H	12343	471413V
1251731TC	12172TB	12371	471709
1251825TB-S	12182TB	12386	471737
1251925TB	12192TB	12407	204507
1251925TB-S	12192TB	12407	204507
1251925TB-V	121982VTB		
1251925VA5	12192VA5-H	12407	204507
1251925VB	12192VB	12407	204507
1251925VH-S	12192VH	12407	204507
1251940VA5	12194VHY	12411	204029
1251940VHY	12194VHY	12411	204029
12519825TB	121982TB	12428	471750
12519825TB-CSV	121982VTB-H	12432	471750V
12519825VH	121982VH	12437	481750
1252025TB	12202TB	12458	471766
1252025TB-S	12202TB	12458	471766
1252025TB-CSV	12202VTB-H	12446	471766V
1252031TC	12203TC	12458	471766
1252031TF	12203TC	12458	471766
1252043TB-CSV	12202VTB	12446	470163

Inch Interchange - Shaft Seals



BOLD NUMBERS ARE EXACT EQUIVALENTS. ALL OTHERS ARE CLOSEST EQUIVALENTS. All PEER Part #'s prefixed with "POS"

PEER	Transcom	CR/SKF	National
1252037TB-S	122043TB-H		473551
12520625TB-S	122062TB	*12531	471787
1252125TB-S	12212TB-H	12545	471795
1252225TC	12222TZ	12577	
12522525SB	12222VB	12577	480165
12522525VB	12222VB	12582	480165
12522550TB-S	12223TC	12577	470165
1252337TB-S	12233TB-H	12614	471808
12523731TC	12233TB	12614	471808
1252437TB-S	122433TB-H	12621	471818
12524437TB	122443TB	12631	471407
12524437TC	122443TB	12631	471407
1252537TB-S	122503TB-H	12637	471833
1292031TM			
1292034TB-T			
1311837TB-S	131183TB-H	13027	473423
1312031TB-S	1312003TB-H	13037	473210
1312131TB-S	131213TB-H	13092	473211
1312231TB-S	131223TB-H	13112	473212
13132031TB-S	131203TB	13052	472826
13721943TM	13194TM		
1371725SM-CS-S	131725SEMY-H	13514	340853
13718231SB-S	13183SB	13537	323138
1371825TB	131872TB	13534	472354
1371831TB-SS-S	131873TB	13535	472354
1371831TF-SS	131873TF	13535	330663
1371931SB-CSP-S	13193PSB	13557	482163N
1372031SB	13203SB	13568	482258
1372031TB	13203TB	13569	472258
1372031TB-V	13203VTB-H	13581	472258V
13721031TB	13213TB	13602	472287
1372131TB-S	132123TB	13650	471192
1372137SC	132123TC	13649	483022
1372231TB-S	13223TB-H	13676	473214
1372331TB-S	13233TB	13739	473215
1372431TB-S	132443TB	13812	471276
1372537TB	132537TB	13865	471835
13725637TB-S	132563TB	13876	473258
1372637TB-S	132623TB-H	13882	472843
1372746SA-S	13274SA-H	13900	450456
1372831TB-S	13283TB	13918	473197
1372846TB-S	13284TB-H	13929	471105
1432131TB	14213TB	14223	473224
1432231TB	14223TB	14247	473016
1432331TB	14233TB	14283	473225
1501918VB	15191VB	14840	443018
1501925TB	15192TB	14824	474276
15019825KB	151982KB	14848	3677&



Inch Interchange - Shaft Seals

BOLD NUMBERS ARE EXACT EQUIVALENTS. ALL OTHERS ARE CLOSEST EQUIVALENTS. All PEER Part #'s prefixed with "POS"

PEER	Transcom	CR/SKF	National
1502031SB-S	15203SB-H	14855	481163
15020437TB-S	152043TB-H	14858	472466
15020631SB-S	152063SB	14864	480991
15020631SB-V-S	152063VSB	14867	
15020631TB-S	152063SB	14864	470451
15020631TB-V-S	152063VSB	14867	
15020637SB-S	152063SB	14864	480991
1502131SB-S	15213SB	14875	483227
1502131TB	15213TB	14876	473227
1502231TB	15223TB	14939	470625
1502231TB-CSV	15223VTB-H	14942	470625V
15022270UB	1522820UB	14970	
15022420UAS		14971	
1502325VH	152372VH	15032	480380
1502331SB-S	152373TB-H	15004	480380
1502331TB-S	152373TB-H	15005	470380
1502331TB-V	15233VTB-H	14994	470380V
1502337SM			
1502339VHY	15233VHY	14975	482591
1502340VB	15234VB	14972	482591
1502350TB	15235TB	14977	472591
1502437TB-S	152433TB-H	15076	471820
1502431SB	152443TL	15092	481344
1502446SA	152443TL	15092	450814
1502531TB-S	15253TB-H	15142	473228
15025650TA	152565TA	15176	410190
1502625VH	15262VH	15190	481857
1502650TB-P	152685PTB-H	15207	470487N
1502743SB-S	15274SA-H	15204	450984
1502746SA-S	15274SA-H	15204	450984
15027531TB-S	15273TB-H	15214	473440
1502846SA-S	15284SA-H	15235	450523
1562137TB	1562137TB-H	15518	473517
1562437TB	156243TB	15592	471821
1562637TB	156263TB-H	15707	471316
1562837TB	156283TB-H	15779	473442
1592446SA	159244SA-H	15955	450065
1592525SB	159252SB-H	15960	482253
1622025TB	16202TB-H	16046	473694
1622131TB	162113TB-H	16047	472419
1621225SB-S	16212SB	16054	481181
1622231TB	16223TB	16061	473230
16223243VHY	162334VHY	16069	473117
1622331TB	16233TB-H	16085	473231
1622431TB	16243TB	16118	473367
1622431TB-CSV-S	16243VTB	16120	473367V
16224431TB	162443TB	16201	471829
16225025VH-S	16253VHY	16270	472758

Inch Interchange - Shaft Seals



BOLD NUMBERS ARE EXACT EQUIVALENTS. ALL OTHERS ARE CLOSEST EQUIVALENTS. All PEER Part #'s prefixed with "POS"

PEER	Transcom	CR/SKF	National
1622531TB	16253TB	16246	473010
1622531TB-P	16253TB	16247	473010N
16225631TB-V-S		16290	
1622525VH	162562VHY	16284	204500
1622543UB	162564VHY	16289	4763S
1622543VHY	162564VHY	16289	4763S
1622631TB	16263TB-H	16315	473232
1622637SC			
16226837SB	162683SB-H	16337	481864
1622725SB	16272SB	16364	474274
1622725TB	162273TB-H	16364	474274
1622725VB	16272VH	16362	480286
1623031TA	16303TA-H	16422	414268
1682431TB	168243TB-H	16680	473445
1682531TB	162503TB	16719	473234
1682550TB	168255TB	16754	470460
1682731TB	16273TB-H	16900	473236
1682331TB	168233TB	16657	473317
17182550VB	171255VB	17146	442251
1712550TB	171255TB	17144	473336
1712550TB-V			
1712550VB	171255VB	17146	442251
17125650VHY	171255VB	17146	442251
1752118SB-S	17211SB	17227	
1752231SA	175223SA	17231	450400
1752331TB-S	172373TB-H	17271	473237
1752331TB-V	172373VTB-H	17261	473237V
1752331VB	17233VB	17257	482126
1752350TC	172355TC		
1752431TB-S	17243TB	17285	471504
1752431TB-CSV-S	17243VTB	17293	471504V
1752446VHY	172443SB	17359	471831
1752531TB-S	17253TB-H	17387	472164
1752531TB-CSV	17253VTB	17381	472164V
1752525VH	172562VH	17415	204502
1752550SA-S	172563SB	17404	450361
17525631SB-S	172563SB	17404	480361
17525650TB-S	172563TB-H	17404	470361
17525631TB	172563TB-H	17404	472193
1752629UA			200335
1752631TB-S	17263TB	17443	472185
17526290UA			200912%
17526837TB	172683TB-H	17484	470334
1752725VH-S		17488	204038
1752735UB	17273UA	17618	200354
1752735VHY	17273VHY	17617	204038
17527531TB	17273TB	17523	472179
17527537TB	172753TB-H	17605	473447



Inch Interchange - Shaft Seals

BOLD NUMBERS ARE EXACT EQUIVALENTS. ALL OTHERS ARE CLOSEST EQUIVALENTS. All PEER Part #'s prefixed with "POS"

PEER	Transcom	CR/SKF	National
1752825VH-S	172873SB	17671	471141
1752831SB-S	172873SB	17653	471141
1752837TB	172873VTB	17645	471141
1752937TB	172993TB-H	17695	473448
1752931TC	17293TC	17678	473448
1753037SC	17303SB	17707	471984
1753037TB-S	173037TB	17699	471984
17530637TB	173063TB	17718	473313
1753131SB	17313SB-H	17746	470088
1753550SA	17355SA-H	17756	455536
1812446SA	182434SA-H	18039	451817
1812637TB	1812683TB-H	18114	471866
1812737TB	181273TB-H	18159	473449
1812837TB	181283TB-H	18242	473450
1812837SB-S	181283SB	18242	480116
1872325SC	182392SC	18549	353120
1872531SB	182503SB	18565	482041
1872531TB	18253TB-H	18565	473454
1872546TBJ-CSP	182564PTBJ		484247
1872631TB	18263TB-H	18581	472439
18726837TB	1872683TB-H	18626	471868
1872731TB	18273TB	18658	472572
18727843TA	18274TA-H	18695	414045
18728337TB-S	182833TB-H		473455
1872831TB	18283TB-H	18734	473238
1873025UB	18302VH	18823	483239
1873025VH	18302VH	18823	483239
1873031TB	183003TB	18817	473239
1873050VB	18305VB		450298
18730631TB	18303TB	18872	473457
1873131TB	18313TB-H	18879	473240
1873137SB-S	18313TB-H	18879	482005
1873137TB	183183TB-H	18899	473458
1932446TB	19244TB-H	19215	470409
19324325TB	19242TB	19210	474269
1932531SB	192565TB-H	19211	710058
1932631TB	19263TB-H	19229	472319
1932731TB	19273TB-H	19264	473241
1932831TB	19283TB-H	19301	472144
1932937TB	19293TB-H	19350	473460
19330637TB-S	1930637TB-H	19380	473461
1933137TB	1931837TB-H	19407	473462
1933537TA	193537TA-H	19449	417474
19382528VB	1932502VB		
1943037UB-S			
2002525TC	20252TC	19754	352541
20026837TB	202683TB-H	19778	471870
20027137TB	202713TB-H	19786	474272

Inch Interchange - Shaft Seals



BOLD NUMBERS ARE EXACT EQUIVALENTS. ALL OTHERS ARE CLOSEST EQUIVALENTS. All PEER Part #'s prefixed with "POS"

PEER	Transcom	CR/SKF	National
2002731TB	20273TB	19832	472492
2002831SB	20283SB	19886	482924
2002837TA-S	20283TA	19896	472924
20028837TB	202883TB	19922	472082
2003031TB	20303TB	19993	472397
2003050SA-S	200303SA	20004	450301
2003025VH	203062VH	20044	204508
20030637TB-S	203063TB-H	20045	473463
20031231TB-S	20313TB	20070	473242
20031237SB-S	20313TB	20070	473242
2003137TA	203153TA	20079	412725
2003243TA-S	20324TA	20109	412027
2003343TA	20334TA	20125	410102
2003543SA	203544TL	20140	455253
2003625VH	20362VH	20148	204506
2003643SA-S		20144	457097
2032856TC	203285TC		
2062843SA	206284SA	20554	451948
2063037TB	206303TB-H	20594	472012
20631843SC			
2063143TA	20314TA-H	20702	416738
2092735VHY	209273VHY	20952	204078
2122737TB	21273TB-H	21061	473204
2122843TB	21284TB	21100	470898
2123037TA	21303TA	21173	472015
2123050TB	21305TC	21164	470303
21230625VH-S	213062VHY	21208	450308
21230650TA	213065TA-H	21213	410308
2123137TB	21313TB-H	21234	472016
21231837TB	213183TB	21267	472409
2123250TB	21325TB		
21233537TA	213353TA-H	21336	413469
21233737TA	213337TA	21353	413470
2123337VB	21333VB	21352	440972
2123343TB	21334TB	21353	413470
2123537TA	21353TA-H	22587	416267
21235450TA	213545TA-H	21358	415349
2163237TC	2163253TC		
2182837TB	218283TB	21736	473244
2183037TB	218303TB-H	21759	472018
2183143TB	218314TB-H	21820	470354
2183337TA	218333TA-H	21890	412943
21833737TA	213373TA-H	21910	413472
2252856TB		540843	
2252943TA	22294TA	22340	471341
22530025SA	22302TA	22368	481272
22530037TB-S	22303TB	22354	471272



Inch Interchange - Shaft Seals

BOLD NUMBERS ARE EXACT EQUIVALENTS. ALL OTHERS ARE CLOSEST EQUIVALENTS. All PEER Part #'s prefixed with "POS"

PEER	Transcom	CR/SKF	National
2253025VH	223062VHY	22392	473473
2253025VHY	223062VHY	22392	473473
2253037TB	223063TB-H	22382	473473
2253137TB-S	22313TB-H	22400	471138
2253150SA	223133TA	22407	450433
2253143SA	223184TA-H	22424	450737
2253143TA	223184TA-H	22425	410737
2253237TB-S	22323TB	22441	472636
22533537TA	223353TA-H	22493	411253
2253337TA	22334TA	22550	412920
2253337TBN	22333TBN	22550	442109
2253337VB	22333VB	22550	442109
2253343TA	22334TA	22532	412920
2253543TA	22354TA-H	22582	411376
2253646TA	22364TA-H	22619	415234
2253743SA-S	22374SA	22626	455259
2253750TA	22375TA-H	22626	415259
2254043SA	22404SA	22647	415254
2313137TB	231313TB-H	23063	472150
2313237TA	231323TA-H	23099	411394
2313337TA	233353TA-H	23152	410694
2313346SA	231334SA-H	23167	450133
2313537TA	231353TA-H	23184	416444
2373037TB	23303TB-H	23641	473573
2373137TB	23313TB-H	23646	470565
23733537TA	23333TA-H	23702	412119
2373343TA	233374TA	23742	413247
2373443TA	23344TA	23756	410987
2373543TA-S	23353SA	23782	416271
2373635SB	23363SB	23839	410825
2373637TA-S	23363TA-H	23841	410825
2373643SA-S	23364SA	23839	455380
2373837TA	23383TA-H	23844	417480
2433137TB	24313TB-H	24255	471887
2433243TA	243324TA-H	24263	412040
2433337TA	243353TA-H	24287	411500
24333737TA	243333TA-H	24320	413478
2433537TA	24353TA-H	24445	417073
2443529UA			
2473235TBY		538550	
2473529UA		24670	6575S
2503137TB	25313TB-H	24881	472029
2503225VH	25322VB	24904	442380
2503237TB	25323TB-H	24898	471271
2503237TB-V	25323VTB-H	24899	471271V
2503243TA-S	25324TA	24911	410519
2503346TA	253354TA-H	24932	410496
25033737TA	253373TB-H	24934	470605

Inch Interchange - Shaft Seals



BOLD NUMBERS ARE EXACT EQUIVALENTS. ALL OTHERS ARE CLOSEST EQUIVALENTS. All PEER Part #'s prefixed with "POS"

PEER	Transcom	CR/SKF	National
2503437TB	25343TB-H	24951	473274
25035037TA-S	25353TA-H	24988	415449
25035037TA-CSV	25353VTA-H	24990	415449V
2503525VH-S	253502VAY	25028	8975S
2503543SA	253544SA	25043	455001
2503543TA	253545TA	25065	415001
2503637TA	25363SA-H	25071	416273
2503743SA	25374SA	25091	455079
2503750TA-S	25374TA	25091	415079
2503846TA	25384TA-H	25102	415082
2504046SA	25404SA-H	25108	455655
2553137VB			
2563637TA	256363TA-H	25641	415988
2563737TA	25373TA-H	25714	417481
2623243SA	26324SA	26110	451143
2623337TA-S	263353TA-H	26124	412871
26233737TA	26333TA	26153	413248
26233746TA	263374TA-H	26141	410708
26235043TA	26354SA	26190	415483
2623637TA	26363TA-H	26211	415458
2623637TB	26363TB	26238	475458
2623643TA-S	26364TA	26211	415003
2623646TB-P-S	26363PTB	26220	475003N
2623737TA	26373TA	26298	417343
2623841UAY	263814UAY	26310	200392
2623846TA	26384TA-H	26328	415007
2624037TA	26403TA-H	26354	417082
2753537SB-S	27353SB-H	27268	486664
2753537TA	27353TA-H	27280	416664
27535343SA	273534SA-H	27284	457291
27535443TA-P-S	273543PTA-H	27295	417484N
2753637TA	27363TA-H	27334	415984
2753725UB	27372VHY	27394	46997S
2753725VH	27372VHY	27394	46997S
2753725VHY	27372VHY	27394	46997S
2753743TA-S	27373TA-H	27370	417316
2753743SA	27374SA	27368	417316
2753843TA-P-S	27384PTA	27452	415009N
2753837TA-S	27384TA-H	27471	415960
2753846SB	27384SA	27467	485009
2754043SA-S	27404PTA	27541	416706
2754043TA-CSP	27404PTA	27565	416706
2843950TB-S	284395TA-H	28425	455511
2873637TA-S	28363TB	28655	415303
2873737TA	28373TA	28687	417344
2873837TA	283873TA-H	28746	417158
2874037TA-S	28403TA-H	28761	416921
2874137TA	28413TA	28817	417134



Inch Interchange - Shaft Seals

BOLD NUMBERS ARE EXACT EQUIVALENTS. ALL OTHERS ARE CLOSEST EQUIVALENTS. All PEER Part #'s prefixed with "POS"

PEER	Transcom	CR/SKF	National
2874446SA	28454SA	28848	455144
2874543SA	28454SA	28848	455144
2874543TA	28454TA	28848	455144
2874643TA	28464TA		
2933737TA	29373TA-H	29224	416956
2934037TA	29403TA-H	29317	416654
2934543SA	29454SA-H	29465	455356
3003743TA-S	30374TA	29872	417349
3003843TA	30384TA-H	29887	417350
3004025VH	30402VH	29968	
3004037TA	30403TA-H	29952	415995
3004037TA-CSV	30403VTA-H	29958	415995V
3004043TA-P	30404TA	29925	415836N
3004046SA	30404SA	29951	455013
3004143SA-S	30414SA-H	30000	457351
3004143TA	30414TA-H	30000	417351
3004243TA	30424TA-H	30055	417487
3004243TA-P-S	30424PTA	30055	415086N
3004350TA-S	30435TA-H	30060	415962
3004543SA	30454SA	30087	415088
3004543TA	30454TA	30095	415088
3004946SA	304946SA-H	30125	455019
3124037TA	31403TA-H	31148	416404
3124137TA	31413TA-H	31173	417621
3124243TA	31424TA-H	31228	416288
3124350TA	31435TA-H	31261	417171
3124643TA	314643TA-H	31299	416297
3124750TA	31475TA-H	31316	416024
3124946TA	31494TA-H	31333	415021
3124946TB	31494-TB	31333	475021
3125246TA	31524TA-H	31353	415394
3184243SA	318424SA	31758	456105
3184543SA	318454SA-H	31855	455336
3224350TBY		538549	
3254037TA	32403TA-H	32344	417433
3254237TB	32423TB	32395	476470
3254350TA	32435TA-H	32424	417181
3254525VH	32452VH	32510	
3254537TA	324537TA-H	32448	418028
3254543TA	32504TA	32502	415137
3254650TA	32465TA-H	32514	417353
3254746TA	32474TA		415577
3254748SA	324754SA-H	32560	456305
3254946TA	32494TA-H	32583	415023
3374137TA	33413TA-H	33645	415442
3374250TA	33425TA-H	33665	416294
3374337TA	33433TA-H	33712	412473
3374643SA	33464SA	33772	486319

Inch Interchange - Shaft Seals



BOLD NUMBERS ARE EXACT EQUIVALENTS. ALL OTHERS ARE CLOSEST EQUIVALENTS. All PEER Part #'s prefixed with "POS"

PEER	Transcom	CR/SKF	National
3374643TA	33464TA	33773	417354
3374946TA	33494TA-H	33837	415025
3504025VB-S		34840	
3504350TA-S	35435TA-H	34868	416624
3504543TA	35454TA	34889	415991
3504546TA	35454TA	34889	415991
3504946TA	35494TA-H	35082	415027
3505143TA	35514TA-H	35095	417495
3505246TA	35524TA-H	35096	415559
3505550TA	35555TA-H		417496
3624337TA	36433TA-H	36157	417698
3624750TA	36475TA-H	36220	415937
3624850TA-S	36485TA-H	36314	417355
3624950TA	36495TA-H	36363	416125
3625243TA	36524TA-H	36382	417499
3754546TA-P-S	37454PTA	37330	415983N
3754750TA	37473TB	37396	415379
3754943TA	37494TA	37533	416339
3755246TA	37524TA-H	37574	415150
3755350TA	375375TA-H		416127
3756050SA	37605SA		
3874737TA	38473TA-H	38653	417210
3874850TA-S	38485TA-H	38673	417211
3874950TA	38495TA-H	38692	416345
3875243SA-S	38524TA	38730	455148
3875243TA-S	38524TA	38731	415148
3875350TA	38535TA-H	38745	415958
3875550TA	38555TA-H	38749	417505
4004862TA	40486TA-H	39851	415187
4004943TA	40494TA-H	39934	415035
4004950TA-S	40494TA-H	39934	415953
4005350TA	40535TA-H	40036	416130
40055556TA	405556TA-H	40049	415036
4005637TA	40563TA-H	40078	417507
4005756TA	40575TA-H	40108	415041
4006250TA	40625TA	40158	417223
4124943SA	41494SA-H	41125	455134
4125150TA	41515TA-H	41170	417511
4125550TA	41555TA-H	41265	417512
4125756TA	41575TA-H	41287	415043
4255250TA-S	42524SA-H	42427	416556
4255237TB	42523TB-H	42419	472157
4255350TA	42535TA-H	42475	415196
4255650TA	42565TA-H	42557	416135
4255756TA	425756TA-H	42573	415045
4255950TA	42595TA-H	42616	416137
4256150TA	42615TA-H	42635	417518



Inch Interchange - Shaft Seals

BOLD NUMBERS ARE EXACT EQUIVALENTS. ALL OTHERS ARE CLOSEST EQUIVALENTS. All PEER Part #'s prefixed with "POS"

PEER	Transcom	CR/SKF	National
4256256TA	426256TA-H	42644	415058
4375756TA	43575TA-H	43751	415047
4376050SA	43605SA	43771	416149
4505243TC	45524TC	44913	327303
4505343TA	45534TA	44920	417530
4506750SA	45675SA		
4507550KA			
4507550TA			
4625756TA	465756TA-H	46200	415371
4685750TA-S	468575TA-H	46800	415284
4756050TA	47605TA	47475	417247
4756256TA	476256TA	47583	415066
4876250TA	48625TA-H	48768	417269
4935950TA-S	49595TA-H	49251	417539
4936250TA	49625TA-H	49301	417273
4936350TA			417540
5006050TA	50605TA-H	49929	415725
5006250TA	50625TA-H	49998	416865
5006350TA	50635TA-H	50138	417278
5006750TA	50675TA	50172	417542
5007550TA	50755TA-H	50195	417545
5126250TA	51625TA-H	51252	417258
5256250TA	52625TA-H	52445	417262
5256556TA	526556TA-H	52488	415645
5256750TA	52675TA-H	52648	417549
5316550TA-S	531655TA-H	53151	417550
5506250TB	55625TB-H	54925	476842
5506556TA	55655TA-H	54931	417254
5506757TA	55675TA-H	54971	416107
5507062TA-S			415610
5627150TA	56715TA	56160	417040
5756757TA	576755TA-H	57510	417362
5877150TA	58715TA-H	58741	416476
5877556SA	58755SA-H	58760	455297
6007550TA	60755TA-H	60028	415072
6127162SA	61716SA-H	61210	455330
6257556SA	627556SA-H	62495	455480
6257750TA	62775TA-H	62535	417562
6257875TA	62787TA-H	62572	415854
6377850TA-S	63785TA-H	63734	417563
6377856TA	637856TA-H	63734	417563
6507556TA	65755TA-H	64994	415294
6508062TA	65806TA-H	65037	416229
6628162TA	66816TA-H	66241	417298
6758062TA	67806TA-H	67515	415327
6758256TA	67825TA-H	67533	417596
6878362SA	68836SA-H	68745	455584
7008062TA	70806TA	70016	416364

Inch Interchange - Shaft Seals



BOLD NUMBERS ARE EXACT EQUIVALENTS. ALL OTHERS ARE CLOSEST EQUIVALENTS. All PEER Part #'s prefixed with "POS"

PEER	Transcom	CR/SKF	National
7008262TA	70826TA-H	70028	417597
7008562TA	70856TA-H	70053	416239
7128656TA	71865TA-H	71245	416077
7258262TA	72826TA-H	72515	416044
7258775TA	72877TA-H	72539	415116
7378875SA	73887SA-H	73745	455117
7379075TA-S	73887SA-H		415317
7508562TA	75856TA-H	75030	415867
7509075TA	75907TA-H	75050	415551
7629162TA	76916TA-H	76255	417598
7759262SA	77926SA-H	77540	455406
8009262TA	80926TA-H	79998	417600
8009562TA	80956TA	80010	417601
80010062TA	801006TA	80038	417602
81210175SA	811017SA-H	81245	455123
85010062TA	851006TA-H	85009	417603
85010562TA	851056TA-H	85015	417604
85010675TA	851067TA-H	85085	416394
86210675TA	861067TA-H	86260	417567
90011075TA	901107TA-H	90036	415090
92511275TA	921127TA-H	92536	415219
95011562TA	951156TA-H	95062	417606
10012062TA	1001206TA	100051	417020
10212275TA	1021227TA-H	102540	417570
10512510TA	1051251TA-H	105051	415227
11012562TA	1101256TA-H	110030	417571
11013075TA	1101307TA-H	110051	415482
11513075TA	1151307TA-H	115021	415077
11513575TA	1151357TA-H	115041	415076
12014075TA	1201407TA-H	120060	417608



Metric Interchange - Shaft Seals

BOLD NUMBERS ARE EXACT EQUIVALENTS. ALL OTHERS ARE CLOSEST EQUIVALENTS. All PEER Part #'s prefixed with "POS"

PEER	Transcom	CR/SKF	National
5156TC	5X15X6TC	1960	5X16X5
8123VC	8X12X3VC	3030	
8167TC	8X16X7TC	3145	220860
8185TC	8X18X5TC	3077	8X18X5
10197TC	10X19X7TC	3940	10X19X7
10227TC	10X22X7TC	3945	10X22X7
10227TF-CSV	10X22X7VTF	3947	10X22X7V
10247TC	10X24X7TC	3950	10X24X7
10257TC	10X25X7TC	3952	10X25X7
10267TC	10X26X7TC	3960	10X26X7
11174TC	11X17X4TC	4327	11X17X4
12195TC	12X19X5TC	4702	12X19X5
12205TC	12X20X4TC	4701	12X20X5
12227TC	12X22X7TC	4707	12X22X7
12247TC	12X24X7TC	4715	12X24X7
12257TC	12X25X7TC	4721	12X25X4.5
12267TC	12X26X7TC	4730	12X26X7
12287TC	12X28X7TC	4752	12X28X7
14224TC	14X22X4TC	5535	
14247TC	14X24X7TC	5412	14X24X7
14287TC	14X28X7TC	5441	14X28X6
15247TC	15X24X7TC	5802	15X24X7
15255TC	15X25X4.5TC	5808	15X25X5
15267TC	15X26X7TC	5807	15X26X7
15287TC	15X28X7TC	5922	15X28X7
15307TC	15X30X7TC	5821	15X30X7
15327TC	15X32X7TC	5837	15X32X7
15357TC	15X35X7TC	5845	15X35X7
16247TC	16X24X7TC	6297	16X24X7
16267TC	16X26X7TC	6408	16X26X7
16287TC	16X28X7TC	6412	16X28X7
16307TC	16X30X7TC	6426	16X30X7
16327TC	16X32X7TC	6435	16X32X7
16357TC	16X35X7TC	6442	16X35X7
17244TB-S	17X24X7SC		
17287TC	17X28X7TC	6614	17X28X7
17295TC	17X29X5TC	6615	17X29X7
17307SC	17X30X7SC	6624	17X30X7
17327TC	17X32X7TC	6633	17X32X7
17358TC	17X35X8TC	6643	17X35X8
17407SC	17X40X7SC	6661	17X40X7
17478TC	17X47X8TC	6680	17X47X8
18287TC	18X28X7TC	7018	18X28X6
18307TC	18X30X7TC	7012	18X30X7
18327TC	18X32X7TC	7007	18X32X7
18357TC	18X35X7TC	7032	18X35X7
19328TC	19X32X8TC	7803	19X32X8
20275TB-S			

Metric Interchange – Shaft Seals



BOLD NUMBERS ARE EXACT EQUIVALENTS. ALL OTHERS ARE CLOSEST EQUIVALENTS. All PEER Part #'s prefixed with "POS"

PEER	Transcom	CR/SKF	National
20307TC	20X30X7TC	7912	20X30X7
20357TC	20X35X7TC	7923	20X35X7
20367TC	20X36X7TC	7924	20X36X7
20407TC	20X40X7TC	7956	20X40X7
20427SC	20X42X7SC	7952	20X42X7
20427TC	20X42X7TC	7954	20X42X7
20477SC	20X47X7SC	7966	20X47X7
22327TC	22X32X7TC	8512	22X32X7
22357TC	22X35X7TC	8522	222220
22358TB-S	22X35X8TB-H	8515	222220
22388TC	22X38X7TC	9722	22X38X8
22408SC	22X40X8SC	8551	22X40X8
22427TC	22X42X7TC	8556	22X42X7
22477TC	22X47X7TC	8573	22X47X7
22478SB-S	22X47X7SC	8570	22X47X7
24358TC	24X35X8TC	9449	24X35X7
24377SC	24X37X7SC	9504	24X37X7
24388TC	24X38X8TC	9508	24X38X7
24407SC	24X40X7SC	9514	24X40X7
24527TC	24X52X10TC	9480	24X52X7
25357SC	25X35X7SC	9708	25X35X7
25357TC	25X35X7TC	9709	25X35X6
25357TB2-S	25X35X7TB2-H		
25357TB2-V-S			
25357TM2-S	0981373TM2-H		
25367TC	25X36X7TC	9710	25X36X7
25366SC-CS			
25377TC	25X37X7TC	9714	25X37X7
25387TC	25X38X7TC	9722	25X38X7
25407SB	25X40X7SC	9725	222540
25408TB2-V-S	25X40X8TB2-H		
25408TC	25X40X8TC	9733	25X40X7
25427TC	25X42X7TC		
25447TC	25X44X7TC		222558
25458TC	25X45X8TC	9767	25X45X8
25467TC	25X46X7TC	10028	25X46X7
2547TBY-S	25X47XTBY-HB-H		
25478TB2-S	25X47X8TB2-H		
25477TC	25X47X7TC	9747	25X47X7
254710TC	25X47X10TC	9757	25X47X7
255210SC	25X52X10SC	9762	25X52X10
25627TC	25X62X7TC	9787	25X62X7
258010TB2-S	25X80X10TB2-H		
26377TC	26X37X7TC	10177	26X37X7
26388TC	26X38X8TC		
26388TC-CS			
26407TC	26X40X7TC	10183	26X40X7
26427TC	26X42X7TC	10188	26X42X7



Metric Interchange - Shaft Seals

BOLD NUMBERS ARE EXACT EQUIVALENTS. ALL OTHERS ARE CLOSEST EQUIVALENTS. All PEER Part #'s prefixed with "POS"

PEER	Transcom	CR/SKF	National
26477SC	*26X47X7TC	10218	26X47X7
27377TC	27X37X7TC	10579	27X37X7
27438TC	27X43X8TC	10640	27X43X8
28387SC	28X38X7SC	10924	28X38X7
28408TC	28X40X8TC	10947	28X40X8
28428TC	28X42X8TC	10922	28X42X8
28477TC	28X47X7TC	10961	28X47X7
29477TC	1141850276TCR2		
30407SB	30X40X7SB	11605	223005
30407TC	30X40X7TC	11602	30X40X7
30427SC	30X42X7SC	11608	30X42X7
30457TC	30X45X7TC	11622	30X45X8
30458SB-S	30X45X8SB	11615	1981
30458SC	30X45X8SC	11622	1981
30467TC	30X46X8TC	11671	30X46X7
30477SB	30X47X7SB	11625	30X47X7
30477TC	30X47X7TC	11624	30X47X7
30488SC	30X48X8SC	11633	30X48X8
30507SC	30X50X8SC	11634	30X50X7
30516SC	30X51X7TC	11842	223035
30528TC	30X52X8TC	11639	30X52X7
305510SC	30X55X10SC	11658	30X55X10
30628TC	30X62X8TC	11676	30X62X7
307210SC	30X72X10TC	11686	30X72X10
32437TC	32X43X7TC	12695	32X43X7
32457TC	32X45X7TC	12711	32X45X7
32477SC	32X47X7SC	12733	32X47X7
32488TC	32X48X8TC	12734	32X48X8
32528TC	32X52X8TC	12674	32X52X7
32528TC-CS			
32728TC	32X72X8TC	12790	32X72X8
33457SC	33X45X7SC	12995	
33506TC	33X50X6TC	12883	33X50X12
34468TC	34X46X8TC	13388	34X45X8
34487TC	34X48X7TC	13425	580388
34528TC	34X52X8TC	13431	34X52X8
35457SC	35X45X7SC	13927	35X45X7
35477TC	35X47X7TC		
35478TC2	35X47X8TC2		
35488TC	35X48X8TC		
35488TC-CS			
35507SC	35X50X7TC	13933	35X50X7
35527SC	35X52X8SC	13948	35X52X7
35547SB	35X54X8TC	13952	35X54X8
35558TC	35X55X8TC	13861	473823
35628TB2-S	35X62X8TB2-H		
356210TC	35X62X10TC	13998	35X62X10
357210TC	35X72X10TC	13896	35X72X10

Metric Interchange – Shaft Seals



BOLD NUMBERS ARE EXACT EQUIVALENTS. ALL OTHERS ARE CLOSEST EQUIVALENTS. All PEER Part #'s prefixed with "POS"

PEER	Transcom	CR/SKF	National
358010TC	35X80X10TC	13863	35X80X8
36477SC	36X47X7TC	14005	36X47X7
36527SC	36X52X7SC	14013	36X52X7
36547TC	36X54X7TC	14177	36X54X7.5
36627TC	36X62X7TC	14052	36X62X7
38507SC	38X50X7SC	14707	30X50X7
38527TC	38X52X7TC	14709	38X52X7
38558TC	38X55X8TC		
38558TC-CS			
386010SC	38X60X10TC	14746	38X60X10
386510TC	38X65X10TC	14748	38X65X8
387210SC	38X72X10SC	14761	38X72X10
387411TC	38X74X11TC	14767	320834
40508SC	40X50X7SC	15747	40X50X8
40527TC	40X52X7TC	15801	40X52X7
40558TC	40X55X8TC	15822	40X55X8
40567TC	40X56X7TC	15829	40X56X7
40589TC	40X58X8TC	15838	40X58X10
406010SC	40X60X10SC	15839	40X60X10
406510SC	40X65X10SC	15852	40X65X10
40688TC	40X68X7TC	15858	40X68X8
40707TB2-S	40X70X7TB2-H		
407010TC	40X70X10TC		
407210TC	40X72X10TC	15868	40X72X7
407512TC	40X75X12TC	15864	712011
408010SC	40X80X10TC	15872	40X80X10
42557TC	42X55X7TC	16495	42X55X7
42567TC	42X56X7TC	16494	42X56X7
42609TC	42X60X9TC		
42609TC-CS			
42628TC	42X62X8TC	16518	710408
426810TC	42X68X10TC	16552	42X68X10
427210TC	42X72X10TC	16561	42X72X10
436010SC	43X60X10SC	16937	320583
43628TC	43X62X8TC	16898	224320
44607TC	44X60X7TC	17143	44X60X7
44728SB	44X72X10TC	17184	224470
45587SC	45X58X7TC	17728	45X58X7
45607SC	45X60X7SC	17741	45X60X7
45628TC	45X62X8TC	17738	45X62X8
45658SC	45X65X8SC	17734	45X65X8
45687TC	45X68X8TC	17684	45X68X7
457210TC	45X72X10TC	17795	45X72X95
45757TC	45X75X7TC	17906	45X75X7
458010TC	45X80X10TC	17798	45X80X10
458510SC	45X85X13SC	17797	45X85X10
48628TC	48X62X8TC	18955	320832



Metric Interchange - Shaft Seals

BOLD NUMBERS ARE EXACT EQUIVALENTS. ALL OTHERS ARE CLOSEST EQUIVALENTS. All PEER Part #'s prefixed with "POS"

PEER	Transcom	CR/SKF	National
486510TC	48X65X10TC	18967	224865
487410TC	48X74X10TC	18974	224874
50627TC	50X62X7TC	19622	225005
50658TC	50X65X8TC		
50688SC	50X68X8SC	19616	50X68X8
50698TB2-S	50X69.85X8TB2-H		
507010TC	50X70X10TC	19723	50X70X9
50728SC	50X72X8SC	19638	50X72X8
507210TB	50X72X10TC	19648	225035
507210TC	50X72X10TC	19648	225035
50808SC	50X80X8TC	19665	50X80X8
50908TC	50X90X8TC	19684	50X90X8
51657TB-S	51X65X7TB	20210	51X65X7
52688SC	52X68X8SC	20426	52X68X8
52709TC	52X70X8TC	20430	52X70X9
52728TC	52X72X8TC	20437	52X72X8
547210TC	54X72X10TC	21318	54X72X10
55688TC	55X68X8TC	21648	55X68X8
55708SB-S	55X70X8SB	21610	55X70X8
55708SB-CSV-S	55X70X8VTC	21611	55X70X8V
55708TC	55X70X8TC	21656	55X70X8
557812TC	55X78X12TC	21632	55X78X10
558010SC	55X80X10SC	21642	55X80X8
558510SC	55X85X10SC	21668	55X85X10
56728TC	56X72X8TC	22038	56X72X7
56758TC	56X75X8TC	*22030	56X75X7
58728SC	58X72X8SC	22816	58X72X8
60758SC	60X75X8SC	23426	60X75X8
60789TC	60X78X9TC	23436	60X78X8
608010TC	60X80X10TC	23438	60X80X8
608212TC	60X82X12TC	23456	60X82X7
60858SC	60X85X8SC	23451	60X85X8
609010SC	60X90X10SC	23466	60X90X10
609010TC	60X90X10TC	23747	60X90X8
609510TC	60X95X10TC	23468	60X95X8
628010SC	62X80X10SC	24626	62X80X10
628510SC	62X85X10SC	24638	62X85X8
629010SC	62X90X10SC	24662	62X90X10
63809TC	63X80X9TC		
63809TC-CS			
639010TC	63X90X10TC	24788	63X90X10
65808TC	65X80X8TC	25416	65X80X8
658510SC	65X85X10SB	25422	65X85X10
658810TC	65X88X10TC	25438	65X88X10
659010SC	65X90X10SC	25428	65X90X10
6510010SC	65X100X10SC	25442	65X100X10
67849TC9-CS	67X84X8AO	26381	68X85X8
689010SC	68X90X10SC	26648	68X90X10

Metric Interchange – Shaft Seals



BOLD NUMBERS ARE EXACT EQUIVALENTS. ALL OTHERS ARE CLOSEST EQUIVALENTS. All PEER Part #'s prefixed with "POS"

PEER	Transcom	CR/SKF	National
70858SC	70X85X8SC	27714	70X85X8
709012TC	70X90X12TC	27636	70X90X7
709212TC	70X92X12TC	27750	70X92X12
709513SC	70X95X13TC	27759	70X95X13
7010010TC	70X100X10TC	27768	70X100X10
72969TC	72X96X9TC	28341	227235
759510TC	75X95X10TC	29521	75X95X10
7510010TC	75X100X10TC	29554	75X100X10
7510513TC	75X105X13TC	29567	75X105X13
7511010TC	75X110X10TC	29581	75X110X10
751208UA			200322
7512013TC	75X120X13TC	29587	75X120X10
7810010SC	78X100X10SC	30725	78X100X10
8010010SC	80X100X10SC	31512	80X100X10
8010510TC	80X105X10TC	31515	80X105X10
8011010TC	80X110X10TC	31560	80X110X10
8511010TB-CSV-S	85X110X12VTF	33426	85X110X12V
8511013TC	85X110X13TC	33431	85X110X12
8511513SC	85X115X13SC	33443	85X115X13
8512012TC	85X120X12TC	33563	85X120X12
9011012SC	90X110X13SC	35411	90X110X12
9011512TB-S	90X115X13TB	35420	90X115X12
9512012TB-V-S	95X120X12VTF	37042	95X120X12V
9512012TC	95X120X12TC	37043	95X120X12
9513012SC	95X130X12SC	37081	95X130X12
10012010SC	100X120X10SC	39118	100X120X10
10012512SC	100X125X12SC	39139	100X125X12
10013012SC	100X130X12SC	39156	100X130X12
10513012SC	105X130X12TC	41430	105X130X12
10514012SC	105X140X12TC	41456	105X140X12
11014012TC	110X140X12TC	43324	110X140X12
11514012SC	115X140X13SC	45223	115X140X12
11514514TC	115X145X14TC	45233	115X145X15
12014013SC	120X140X10SC	47212	120X140X13
12015012SC	120X150X12TC	47252	120X150X12
12015012TF-CSV	120X150X12VTF	47254	120X150X12V
12515012TC	125X150X12TC	49213	125X150X12
12516012SC	125X160X12TC	49268	125X160X12
13016012SC	130X160X12SC	51130	130X160X12
14017012TC	140X170X12TC	55113	140X170X12
14017013SC	140X170X13SC	55119	140X170X15
15018015TC	150X180X15TC	59076	150X180X15
16018510SC	160X185X10TC	62930	160X185X10
16019015SC	160X190X15TC	62940	160X190X15
18021015SC	180X210X15SB	70805	180X210X15
19023016TC	190X230X16TC	594857	190X230X16
22025015SC	220X250X15SC	86615	220X250X15
24027015SC	240X270X15SC	94495	240X270X15



Oil Bath Seals & Materials and Specifications

OIL BATH SEALS

Introduction

An Oil Bath Seal is a special style of seal designed specifically for the heavy duty truck and trailer industry. The PEER line of Oil Bath Seals has been developed to meet the long service life, simple handling and installation, superior quality and economy that are expected in today's heavy duty truck and trailer market.

MATERIALS AND SPECIFICATIONS

BASE POLYMER	TEMPERATURE RANGE	ADVANTAGES	DISADVANTAGES
NITRILE	-40° to 250°F -40° to 121°C	Good resistance to petroleum oils, water, silicone oils, greases and glycol based fluids. Good abrasion resistance, cold flow and tear resistance.	Poor resistance to ozone and weather aging.
POLYACRYLATE	-30° to 300°F -34° to 149°C	Good resistance to mineral oils, hypoid gear oils, E.P. additives, greases, aging and flex cracking.	Fair cold temperature limit. Lower mechanical strength. Higher cost than Nitrile. Poor dry running ability and water resistance.
FLUOROELASTOMER	-40° to 400°F -40° to 204°C	Good temperature resistance. Compatible with a wide range of fluids. Commonly chosen as a high temperature replacement for Nitrile or Polyacrylate.	Fair resistance to water and dry running. High cost.

CASE				
SAE No.	AISI No.	Material	Application	Cost
1006 - 1010	1006 - 1010	Carbon steel	General	Low
30304	304	Stainless steel	Corrosion resistant conditions	High

SPRING				
SAE No.	AISI No.	Material	Application	Cost
1070 - 1080	1070 - 1080	Piano wire	General	Low
30304	304	Stainless steel	Corrosion resistant conditions	High

POBS 5000 Series

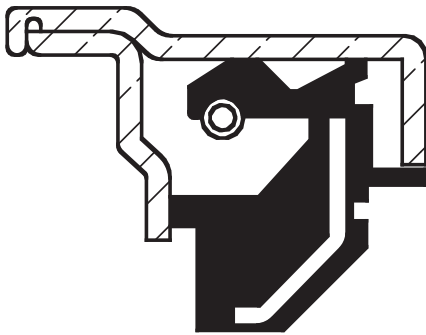

Metal O.D. Style

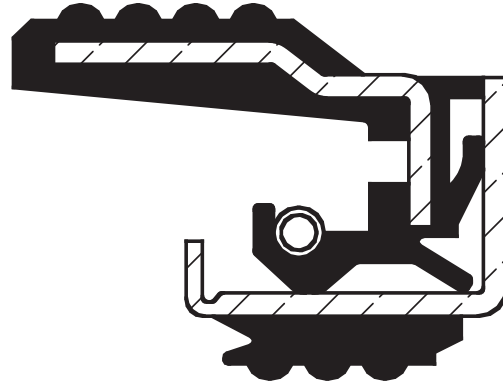

Rubber O.D. Style

POBS 7000 Series

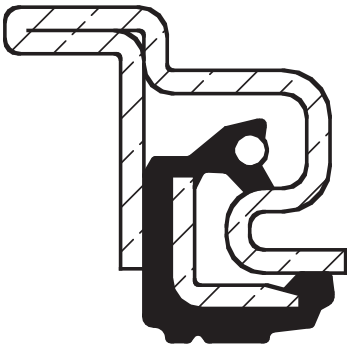

Metal O.D. Style



Metal O.D. Style



Oil Bath Seal Installation

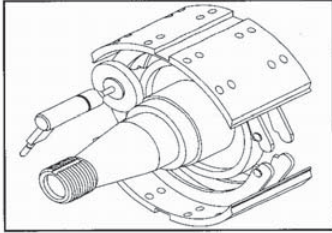

1. Inspect the spindle shoulder for nicks and roughness. Use a file or cleaning tool to remove all burrs. Smooth out with an emery cloth and wipe clean.

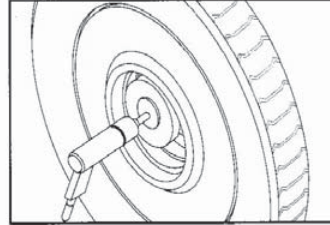

2. Inspect the inner hub bore and remove all burrs from the leading edge with a cleaning tool or emery cloth and wipe clean.

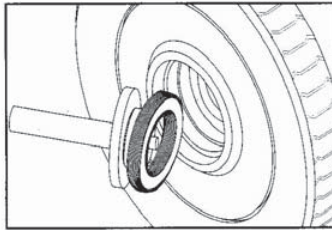

3. Select the correct seal adapter plate and bearing pilot and install on the tool handle. Pre-lube the inner bearing cone and place it into the bearing cup bore.

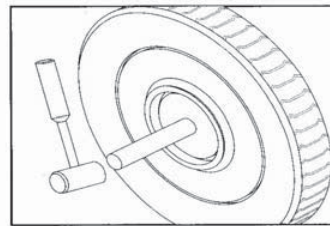

4. Lightly lubricate seal O.D. with clean oil. Place oil bath seal into hub bore. Hold tool straight and drive seal with firm blow until sound of impact changes as seal bottoms out. Check to see that seal is squarely in position and that inner bearing rotates freely. Apply thin layer of sealant to O.D. of spindle shoulder and I.D. of seal.

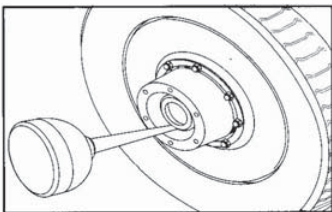

5. With the wheel mounted on a dolly, carefully align the hub assembly with the spindle and push into the correct position. Fill the hub with lubricant and install the hub.

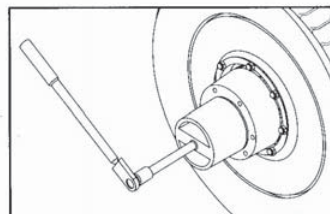

6. Lubricate the outer bearing and install in the cup bore. Adjust the bearings to the bearing or vehicle manufacturer's specifications. Install the lock washer and outer nut. Install the hub cap using a new gasket and fill the cavity to the proper level with clean oil.

Oil Bath Seal Parts Listing & Interchange-POBS 5000 Series



Exact Equivalents							Close Equivalents	
PEER Part #	CR/SKF	Shaft	Bore	Seal O.D.	Width	Lip Mat.	National	Stemco
POBS4997	27438	2.750	3.779	3.784	0.762	Nitrile	370352A	
POBS4998	28758	2.875	3.875	3.881	0.781	Nitrile	370150A	
POBS4999	28820	2.875	4.126	4.131	0.844	Nitrile	370010A	
POBS5000	28832	2.875	4.176	4.181	0.844	Nitrile	370054A	
POBS5001	31175	3.125	4.126	4.131	0.781	Nitrile	370145A	
POBS5002	31182	3.125	4.126	4.131	0.526	Nitrile	370145A	
POBS5003	31244	3.125	4.373	4.378	0.781	Nitrile		
POBS5004	31264	3.125	4.400	4.405	0.844	Nitrile		
POBS5005	31266	3.125	4.438	4.442	0.781	Nitrile		
POBS5006	31281	3.125	4.500	4.506	0.672	Nitrile	370014A	
POBS5007	31307	3.125	4.626	4.631	0.672	Nitrile	370046A	
POBS5008	32470	3.250	4.501	4.506	0.672	Nitrile	370018A	
POBS5009	34386	3.438	4.757	4.770	0.700	Nitrile	370047A	
POBS5010	34387	3.438	4.757	4.762	0.859	Nitrile	370047A	309-0935
POBS5011	34972	3.500	4.547	4.557	0.900	Nitrile	370132A	
POBS5012	34975	3.500	4.547	4.552	0.862	Nitrile	370132A	308-0863
POBS5013	34999	3.500	4.750	4.765	0.706	Nitrile	370169A	
POBS5014	35000	3.500	4.626	4.631	0.986	Nitrile	370169A	
POBS5016	35059	3.500	4.842	4.854	0.903	Nitrile	370001A	
POBS5017	35060	3.500	4.814	4.819	0.906	Nitrile		
POBS5018	35066	3.500	4.842	4.847	0.904	Nitrile	370001A	308-0836
POBS5019	35072	3.500	4.852	4.857	0.904	Nitrile	370001A	
POBS5020	35075	3.500	5.000	5.006	0.891	Nitrile	370002A	
POBS5022	35820	3.577	4.811	4.819	0.906	Viton		
POBS5023	36274	3.625	4.755	4.760	1.250	Nitrile		
POBS5024	36285	3.625	4.813	4.819	0.906	Nitrile	370012A	
POBS5025	36357	3.625	5.000	5.014	0.830	Nitrile	370011A	
POBS5026	36358	3.625	5.000	5.006	0.859	Nitrile	370011A	
POBS5027	36365	3.625	5.001	5.006	0.891	Nitrile	370011A	
POBS5028	38709	3.875	5.129	5.134	0.844	Nitrile	370033A	
POBS5029	38736	3.875	5.248	5.255	0.844	Nitrile		
POBS5030	38747	3.875	5.376	5.381	1.016	Nitrile	370165A	
POBS5031	38748	3.875	5.501	5.514	0.892	Nitrile	370024A	
POBS5032	38750	3.875	5.501	5.506	0.938	Nitrile	370024A	309-0915
POBS5033	38779	3.875	5.691	5.704	0.892	Nitrile	370023A	
POBS5034	38780	3.875	5.691	5.696	0.938	Nitrile	370023A	309-0912
POBS5035	38782	3.875	5.691	5.696	0.938	Viton	370023A	
POBS5037	39380	3.938	5.374	5.379	1.016	Nitrile	370008A	
POBS5038	39420	3.938	5.501	5.506	0.938	Nitrile	370009A	
POBS5040	39425	3.938	5.504	5.509	1.016	Nitrile	370009A	
POBS5041	39426	3.938	5.512	5.526	0.591	Nitrile	370009A	
POBS5043	39977	4.000	5.122	5.137	0.953	Nitrile		
POBS5044	39988	4.000	5.126	5.131	1.047	Nitrile		
POBS5045	39990	4.000	5.126	5.131	1.047	Viton		
POBS5046	40040	4.000	5.376	5.381	1.016	Nitrile	370015A	
POBS5047	40086	4.000	5.626	5.631	0.688	Nitrile	370066A	



Oil Bath Seal Parts Listing & Interchange-POBS 5000 Series

Exact Equivalents							Close Equivalents	
PEER Part #	CR/SKF	Shaft	Bore	Seal O.D.	Width	Lip Mat.	National	Stemco
POBS5048	40088	4.000	5.626	5.639	0.688	Nitrile	370066A	
POBS5050	40133	4.000	5.754	5.767	0.995	Nitrile	370036A	
POBS5051	40136	4.000	5.754	5.759	1.079	Nitrile	370036A	307-0713
POBS5052	40139	4.000	5.760	5.765	1.079	Nitrile	370036A	
POBS5053	40146	4.000	5.754	5.759	1.079	Viton	370036A	
POBS5055	42550	4.250	5.501	5.506	0.938	Nitrile		
POBS5056	42622	4.250	6.009	6.025	0.971	Nitrile	370065A	
POBS5057	42623	4.250	6.009	6.014	0.984	Nitrile	370065A	307-0723
POBS5058	42624	4.250	6.043	6.048	0.984	Nitrile	370107A	
POBS5059	42625	4.250	6.009	6.020	1.122	Nitrile	370065A	
POBS5060	42630	4.250	6.009	6.014	0.984	Viton	370065A	
POBS5062	42671	4.250	6.254	6.267	1.245	Nitrile	370031A	
POBS5063	42672	4.250	6.254	6.259	1.250	Nitrile	370031A	309-0904
POBS5064	42800	4.266	6.066	6.071	0.875	Nitrile	370030A	
POBS5065	43752	4.375	5.751	5.756	1.016	Nitrile	370037A	307-0744
POBS5066	43753	4.375	5.751	5.764	0.995	Nitrile	370037A	
POBS5067	43763	4.375	5.905	5.918	1.000	Nitrile	370048A	
POBS5068	43764	4.375	5.905	5.910	1.000	Nitrile	370048A	308-0864
POBS5070	43800	4.375	6.003	6.008	1.047	Nitrile		
POBS5071	43860	4.375	6.254	6.259	0.922	Nitrile	370019A	309-0965
POBS5072	43861	4.375	6.254	6.264	0.920	Nitrile	370019A	
POBS5073	43865	4.375	6.254	6.259	1.047	Nitrile	370019A	
POBS5074	43875	4.375	6.311	6.316	1.125	Nitrile	370034A	
POBS5075	44919	4.500	5.375	5.389	0.975	Nitrile	370124A	
POBS5076	44922	4.500	5.375	5.381	0.984	Nitrile	370124A	308-0853
POBS5077	44963	4.500	5.501	5.515	0.750	Nitrile	370178A	
POBS5078	44964	4.500	5.501	5.506	0.750	Nitrile	370178A	
POBS5079	45010	4.500	5.501	5.506	0.938	Nitrile	370178A	
POBS5080	45097	4.500	5.751	5.764	0.767	Nitrile	370022A	
POBS5081	45099	4.500	5.751	5.756	1.016	Nitrile	370022A	309-0903
POBS5082	45100	4.500	5.751	5.756	1.016	Nitrile	370022A	
POBS5083	45102	4.500	5.876	5.890	1.009	Nitrile	370131A	
POBS5084	45103	4.500	5.876	5.881	0.984	Nitrile	370131A	308-0855
POBS5085	45108	4.500	5.751	5.756	1.016	Viton	370022A	
POBS5086	45152	4.500	6.311	6.316	1.125	Nitrile	370086A	
POBS5087	45158	4.500	6.254	6.264	0.750	Nitrile	370021A	
POBS5088	45160	4.500	6.254	6.259	1.047	Nitrile	370021A	309-0964
POBS5089	45162	4.500	6.441	6.446	0.938	Nitrile	370192A	
POBS5090	45163	4.500	6.379	6.384	0.938	Nitrile		
POBS5091	46304	4.625	6.001	6.014	0.912	Nitrile	370025A	
POBS5092	46305	4.625	6.001	6.006	1.063	Nitrile	370025A	307-0743
POBS5093	46306	4.625	6.001	6.006	1.063	Viton	370025A	
POBS5095	46390	4.635	6.009	6.014	1.031	Nitrile	370026A	
POBS5097	46396	4.625	6.623	6.629	1.093	Nitrile	370051A	
POBS5098	47245	4.724	5.906	5.920	0.590	Nitrile	370220A	
POBS5099	47483	4.750	6.001	6.006	1.063	Nitrile		

Oil Bath Seal Parts Listing & Interchange-POBS 5000 Series



Exact Equivalents							Close Equivalents	
PEER Part #	CR/SKF	Shaft	Bore	Seal O.D.	Width	Lip Mat.	National	Stemco
POBS5100	47690	4.766	6.001	6.006	1.063	Nitrile	370181A	
POBS5102	47695	4.767	6.308	6.326	1.420	Nitrile	370003A	
POBS5103	47696	4.766	6.311	6.316	1.125	Viton	370003A	
POBS5104	47697	4.766	6.311	6.316	1.125	Nitrile	370003A	309-0973
POBS5105	47698	4.767	6.313	6.320	1.125	Nitrile	370003A	
POBS5106	47699	4.766	7.000	7.006	1.250	Nitrile	370006A	309-0970
POBS5107	48000	4.766	6.254	6.259	1.047	Nitrile	370005A	309-0960
POBS5108	48001	4.766	6.254	6.264	0.795	Nitrile	370005A	
POBS5109	48297	4.824	6.311	6.316	1.125	Nitrile	370027A	
POBS5110	48298	4.824	6.501	6.506	1.125	Nitrile		
POBS5111	48690	4.875	6.001	6.006	0.875	Nitrile	370195A	
POBS5112	48691	4.875	6.001	6.006	0.875	Viton	370195A	
POBS5113	48792	4.875	6.254	6.259	1.047	Nitrile	370057A	
POBS5114	48794	4.875	6.379	6.384	0.938	Nitrile	370007A	
POBS5115	48796	4.875	6.441	6.446	0.938	Nitrile	370057A	
POBS5116	48884	4.875	6.503	6.508	1.063	Nitrile	370121A	
POBS5117	50124	5.000	6.254	6.259	1.047	Nitrile	370028A	
POBS5118	50190	5.000	7.380	7.385	1.875	Nitrile		
POBS5119	52658	5.250	7.376	7.381	0.945	Nitrile	370069A	309-0948
POBS5120	52660	5.250	7.378	7.383	1.875	Nitrile	370069A	
POBS5121	52664	5.250	7.379	7.385	2.500	Nitrile	370069A	
POBS5122	55122	5.512	6.693	6.707	0.591	Nitrile		
POBS5123	55172	5.500	7.126	7.132	1.187	Nitrile	370043A	
POBS5124	55177	5.500	7.250	7.256	1.187	Nitrile	370120A	



Oil Bath Seal Parts Listing & Interchange-POBS 7000 Series

Exact Equivalents							Close Equivalents	
PEER Part #	National	Shaft	Bore	Seal O.D.	Width	Lip Mat.	CR/SKF	Stemco
POBS7001	370001A	3.500	4.842	4.848	0.925	Nitrile	35066	308-0836
POBS7002	370002A	3.500	5.000	5.006	1.000	Nitrile	35075	
POBS7003	370003A	4.765	6.311	6.318	1.078	Nitrile	47697	309-0973
POBS7004	370004A	4.812	6.500	6.507	0.865	Nitrile	48884	
POBS7005	370005A	4.765	6.251	6.265	0.605	Nitrile	48000	309-0960
POBS7006	370006A	4.765	6.999	7.006	1.250	Nitrile	47699	309-0970
POBS7007	370007A	4.875	6.373	6.379	0.921	Nitrile	48794	
POBS7008	370008A	3.937	5.372	5.378	1.015	Nitrile	39380	
POBS7009	370009A	3.937	5.501	5.507	0.937	Nitrile	39420	
POBS7010	370010A	2.875	4.125	4.130	0.842	Nitrile	28820	
POBS7011	370011A	3.625	5.000	5.014	0.875	Nitrile	36365	
POBS7012	370012A	3.625	4.810	4.823	0.921	Nitrile	36285	
POBS7013	370013A	3.312	5.000	5.006	0.937	Nitrile		
POBS7014	370014A	3.125	4.500	4.506	0.605	Nitrile	31281	
POBS7015	370015A	4.000	5.375	5.381	1.000	Nitrile	40040	
POBS7018	370018A	3.250	4.500	4.506	0.605	Nitrile	32470	
POBS7019	370019A	4.375	6.251	6.256	0.605	Nitrile	43860	309-0965
POBS7020	370020A	4.500	6.000	6.007	0.984	Nitrile	43800	
POBS7021	370021A	4.500	6.251	6.265	0.610	Nitrile	45160	309-0964
POBS7022	370022A	4.500	5.750	5.756	0.960	Nitrile	45099	309-0903
POBS7023	370023A	3.875	5.690	5.706	0.875	Nitrile	38780	309-0912
POBS7024	370024A	3.875	5.501	5.515	0.875	Nitrile	38750	309-0915
POBS7025	370025A	4.625	5.999	6.008	0.840	Nitrile	46305	307-0743
POBS7026	370026A	4.635	6.007	6.014	0.937	Nitrile	46390	
POBS7027	370027A	4.812	6.311	6.316	1.062	Nitrile	48297	
POBS7028	370028A	5.000	6.250	6.256	1.375	Nitrile	50124	
POBS7029	370029A	3.187	5.000	5.006	0.765	Nitrile		
POBS7030	370030A	4.265	6.064	6.071	0.605	Nitrile	42800	
POBS7031	370031A	4.250	6.250	6.256	1.188	Nitrile	42672	309-0904
POBS7033	370033A	3.875	5.126	5.132	0.605	Nitrile	39988	
POBS7034	370034A	4.375	6.311	6.317	1.090	Nitrile	43875	
POBS7036	370036A	4.000	5.757	5.772	0.930	Nitrile	40136	307-0713
POBS7037	370037A	4.375	5.757	5.763	1.000	Nitrile	43752	307-0744
POBS7038	370038A	5.000	7.437	7.444	0.605	Nitrile		
POBS7039	370039A	5.500	7.437	7.444	1.000	Nitrile		
POBS7043	370043A	5.500	7.125	7.132	1.187	Nitrile	55172	
POBS7046	370046A	3.125	4.625	4.631	0.605	Nitrile	31307	
POBS7047	370047A	3.437	4.755	4.761	0.605	Nitrile	34387	309-0935
POBS7048	370048A	4.375	5.905	5.911	1.000	Nitrile	43764	308-0864
POBS7051	370051A	4.625	6.622	6.629	1.093	Nitrile	46396	
POBS7054	370054A	2.875	4.175	4.181	0.822	Nitrile	28832	
POBS7057	370057A	4.875	6.437	6.444	0.921	Nitrile	48796	
POBS7063	370063A	5.000	6.250	6.256	0.605	Nitrile		
POBS7064	370064A	5.625	7.186	7.194	0.906	Nitrile		
POBS7065	370065A	4.250	6.008	6.022	1.000	Nitrile	42623	307-0723
POBS7066	370066A	4.000	5.626	5.632	0.605	Nitrile	40086	
POBS7069	370069A	5.250	7.375	7.386	1.000	Nitrile	52658	309-0948
POBS7077	370077A	6.000	7.875	7.881	0.605	Nitrile		

Oil Bath Seal Parts Listing & Interchange-POBS 7000 Series



Exact Equivalents							Close Equivalents	
PEER Part #	National	Shaft	Bore	Seal O.D.	Width	Lip Mat.	CR/SKF	Stemco
POBS7078	370078A	4.500	6.622	6.629	1.093	Nitrile		
POBS7082	370082A	7.375	9.054	9.063	1.062	Nitrile		
POBS7086	370086A	4.500	6.310	6.316	1.175	Nitrile	45152	
POBS7087	370087A	4.000	5.248	5.254	0.605	Nitrile		
POBS7094	370094A	4.125	5.375	5.381	0.605	Nitrile		
POBS7106	370106A	4.166	5.500	5.506	0.605	Nitrile	42550	
POBS7107	370107A	4.250	6.035	6.047	0.915	Nitrile	42624	
POBS7109	370109A	4.875	6.622	6.629	1.000	Nitrile		
POBS7119	370119A	4.375	6.251	6.256	0.605	Nitrile		
POBS7120	370120A	5.500	7.250	7.256	1.187	Nitrile	55177	
POBS7121	370121A	4.875	6.500	6.506	1.000	Nitrile	48884	
POBS7124	370124A	4.500	5.374	5.391	0.984	Nitrile	44922	308-0853
POBS7127	370127A	2.752	3.937	3.942	0.565	Nitrile		
POBS7131	370131A	4.500	5.876	5.892	0.984	Nitrile	45103	308-0855
POBS7132	370132A	3.500	4.543	4.558	0.788	Nitrile	34975	308-0863
POBS7145	370145A	3.125	4.174	4.188	0.500	Nitrile	31175	
POBS7149	370149A	6.625	8.007	8.014	0.605	Nitrile		
POBS7150	370150A	2.875	3.875	3.889	0.500	Nitrile	28758	
POBS7151	370151A	7.875	10.234	10.242	0.605	Nitrile	78790	
POBS7154	370154A	5.000	7.000	7.006	1.000	Nitrile		
POBS7155	370155A	2.740	3.937	3.942	0.565	Nitrile		
POBS7165	370165A	3.875	5.376	5.381	0.985	Nitrile	38747	
POBS7166	370166A	5.000	6.622	6.629	1.093	Nitrile		
POBS7169	370169A	3.500	4.751	4.757	0.605	Nitrile	34999	
POBS7173	370173A	4.765	6.250	6.257	1.050	Nitrile	48000	309-0960
POBS7175	370175A	7.250	8.750	8.758	0.605	Nitrile	72539	
POBS7178	370178A	4.500	5.500	5.515	0.675	Nitrile	44964	
POBS7179	370179A	3.500	4.450	4.456	0.843	Nitrile		
POBS7181	370181A	4.765	5.999	6.006	1.031	Nitrile	47690	
POBS7182	370182A	4.375	5.905	5.910	1.000	Nitrile		308-0864
POBS7191	370191A	3.312	4.501	4.506	0.605	Nitrile		
POBS7192	370192A	4.500	6.441	6.447	0.937	Nitrile	45162	
POBS7195	370195A	4.875	6.001	6.015	0.625	Nitrile	48690	
POBS7198	370198A	4.040	5.122	5.130	0.945	Nitrile		
POBS7199	370199A	2.359	3.938	3.952	0.575	Viton		
POBS7211	370211A	2.948	4.725	4.738	0.526	Nitrile		
POBS7212	370212A	3.539	5.277	5.291	0.604	Viton		
POBS7215	370215A	5.000	7.000	7.015	1.130	Viton		
POBS7216	370216A	4.625	5.999	6.006	0.890	Nitrile		
POBS7219	370219A	2.250	3.372	3.377	0.475	Nitrile		
POBS7220	370220A	119,99	150,01	150,16	14,99	Nitrile		
POBS7223	370223A	2.938	3.750	3.765	0.530	Nitrile		
POBS7224	370224A	4.768	6.999	7.039	0.735	Nitrile		
POBS7338	370338A	4.375	5.757	5.798	0.600	Nitrile	43752	307-0744
POBS7349	370349A	4.000	5.757	5.798	0.600	Nitrile	40136	307-0713
POBS7352	370352A	2.750	3.779	3.792	0.767	Nitrile		
POBS7590	376590A	4.250	6.048		0.680	Nitrile	42623	307-0723



USA

PEER Bearing Headquarters
2200 Norman Drive
Waukegan, IL 60085
USA
Ph: 1 847 578 1000
info@peerbearing.com

China

PEER China — SPZ
Rm 2306 Fortune Times Building #1438 North
Shaanxi Road Putuo District, Shanghai,
China
Ph: +86 21 61484816
sales@peerchina.com

Italy

PEER Bearing S.R.L.
Via Paolo Nanni Costa, 12/3 A
40133 Bologna
Italy
Europe.info@peerbearing.com

Germany

PEER Bearing GmbH
Mainzer Landstraße 47
60329 Frankfurt am Main
Germany
Ph: +49 (0) 69 95 92 54 90
Europe.info@peerbearing.com

Brazil

Alameda Mamoré, 535-cj. 408/410
Alphaville—Barueri—SP Brazil
CEP 06454-040
Ph: +55 11 4166 5650
LAM.info@peerbearing.com

United Kingdom

Unit 6, Chelworth Park
Chelworth Road
Cricklade, Wilshire
SN6 6HE, England
Ph: +44 (0) 1793 759459
Europe.info@peerbearing.com